

The logo for EL-O-MATIC, featuring the brand name in a bold, black, sans-serif font with a registered trademark symbol. The letters 'E', 'O', and 'M' are slightly larger than the others. The background of the entire page is a photograph of an industrial refinery or chemical plant at sunset, with tall distillation columns and piping silhouetted against a bright orange sky. In the foreground, three yellow actuators are displayed: a large one with a red handwheel on the left, a medium-sized one in the center, and a smaller one on the right.

Pneumatic & Electric Actuator Product Guide

System
Compatible
Products for
Worldwide
Flow Control



EMERSON
Process Management

Contents

Valve automation systems



Introduction

About El-O-Matic 1

Pneumatic products

Pneumatic actuators 3

Special versions 6

Pneumatic accessories 7

BUS-communication, pneumatic actuators 9

Posiflex positioners 10

Electric/electronic products

ELQ Electric actuators 12

BUS-communication electric actuators 14

EL Electric actuators 15

Torques and technical data

Pneumatic actuators 18

ELQ Electric actuators 20

EL Electric actuators 21

About El-O-Matic

El-O-Matic develops and manufactures actuators for the automation of industrial valves. Our product range includes pneumatic actuators, electric actuators and a wide range of control accessories, such as switch boxes for position indication, solenoid valves for control signalling and positioners for modulating control. Product development is based on modular construction that allows for fast delivery from stock components and easy upgrade to fully-fledged control units. All actuators can be provided with electronic controls for problem-free communication with field buses or other digital systems.

History

El-O-Matic was established in 1973. Initially as a subcontract machine shop, the company soon specialised in the manufacture of pneumatic actuators. The growing need for process automation led to the development and production of accessories, such as switch boxes and valve positioners. The year 1987 saw the production of the first electric actuators.

National Units

The El-O-Matic world wide network was quickly established, in 1978 - just five years after the company was founded - the first national unit was opened in Germany. This was followed by units in the U.S.A (1982), United Kingdom and Singapore (1985), India (1990), and South Africa (1994).

El-O-Matic now has an extensive international network of sales offices and distributors, providing efficient logistics and guaranteeing world wide availability.

Emerson Electric

In 1995 the company was acquired by Emerson Electric, an American multinational conglomerate consisting of more than 300 companies and divisions.



Valve Automation Division

In 2001 Emerson Electric Co. has announced the formation of the Valve Automation Division of Emerson Process Management, a new operating division that consolidates the company's vast array of valve automation products and services. The new division brings together well-known industry leaders Bettis Actuators and Controls, El-O-Matic International, and Bettis subsidiaries Hytork International, Shafer Valve Operating Systems, and Dantorque.

For El-O-Matic, the merger provides all the resources for continued expansion and growth. Our engineering development makes regular use of the gigantic reservoir of process-automation knowledge available within Emerson's Industrial Automation divisions.

Some figures

El-O-Matic is one of the world's largest specialised manufacturers of valve actuators. Our main production facility is located in Hengelo, in the Netherlands.

In addition, we have three main distribution centres:

- The Netherlands (Hengelo), serving Europe, the Middle East and Africa
- USA (Tampa FL), serving North, Central and South America.
- Singapore, serving Asia and the Pacific Area.

Our local service organisations are listed on the back of this brochure.

Since the Emerson acquisition, we have been part of an enterprise with a total turnover exceeding 14.3 billion US-dollars (1999).



EMERSON
Process Management



Policy

The process industry is in a constant state of change. The main developments in recent years have been the application of digital controls and the introduction of field-bus systems. Digital technology has dramatically changed the verification and control of process events and with the two-way communication provided by fieldbus and the ability to decentralise many of the control functions means that the actual cost of production is reduced. This is achieved at the same time as providing systems, which are more flexible, more accurate and less sensitive to faults.

Innovation

El-O-Matic strives to maintain its leadership with these new developments. Though traditionally a manufacturer of actuators, our policy continues to be focused on the supply of all the automation components located between the hardware of the valve and the

software of the process-control system. This means a continuous activity of new development and product innovation.

Fit and forget

One of the main design parameters in the development of our products is the fit and forget principle: they must be easy to install and then function faultlessly through a long working life, also the addition of ancillaries must be quick and easy to install. This is made possible by the high degree of modular construction in our products.

Modular construction

Our actuators and accessories are mainly made up of standard modules. This means that they can be assembled - and delivered - fast.

Standard products

In order to meet new and ever demanding market requirements, our products are the subject of continuous development and improvement.

2001	New integrated actuator concept	
1997	Introduction of the ELQ electric actuator.	
1994	Introduction of Posiflex series valve positioners.	
1987	Development of EL series electric actuators.	
1983	Development of E series pneumatic actuators.	
1978	Opening of first national unit in Germany	
1973	Development of P series pneumatic actuators.	



Pneumatic Actuators & Accessories

Pneumatic actuators are required to operate in a wide variety of applications; they have to function first time every time, often under very difficult circumstances. One actuator may perform hundreds of cycles 24 hours a day, whereas another may open and close just once a month - then may stay open for months on end, but still be ready to shut down instantly on a failure signal.

The extremes of temperature, harsh duty and corrosive atmospheres where actuators are often applied demand the highest attention to the quality of design and manufacture.

EL-O-MATIC®
INTERNATIONAL

Pneumatic actuators



Optimum performance

We realise that the performance of our pneumatic actuators is vitally important to your production process. An actuator that does not function well often has serious consequences for the outcome of the process. That is why quality has been our primary concept in actuator development. El-O-Matic pneumatic actuators are reliable, quality products, continuously providing optimum performance under all circumstances.

Standard Specification

- Pressure 0.2 to 8 bar
- Temperature -20°C to +80°C
- Materials Housing: Aluminium alloy
Shaft: Hard anodised aluminium alloy
- Finish Polyester non-TGIC based powder coating
- Lifespan Minimum of 500,000 cycles

Features

- For application to ball, plug and butterfly valves.
- Can be used in other quarter-turn applications, such as dampers and pressure regulators.
- Actuators are made of high duty aluminium alloys, providing optimum strength and corrosion resistance.
- Compact rack & pinion design.
- Can be supplied in single (spring return) or double acting versions.
- Choice of twelve sizes, with a torque range from 12 to 4000 Nm.
- Mounting for solenoid valves and position signallers to the NAMUR standard (VDI/VDE 3845).
- Valve mounting and drive dimensions to the ISO 5211 or DIN 3337
- Drive shaft provided with insert, for low cost, versatile direct valve mountings.
- Anti-blow-out shaft.

Operating principle

Pneumatic actuators come in two versions: double acting and single acting (spring return). Both versions are designed in such a way that (with the exception of the position indicator) there are no moving parts on the outside. This makes them safe, easy to install and virtually maintenance free. Furthermore, the compact rack



and pinion construction means that actuators are lightweight and occupy a minimum of space.

Ample choice of spring packages

Spring return, single acting actuators are used in most safety systems. Their ability to automatically return the valve to its fail-safe position on air failure provides the vital link for ultimate system shut down. El-O-Matic spring return actuators have modular spring packages, which enable them to be easily applied to a wide variety of supply pressures and operating conditions.

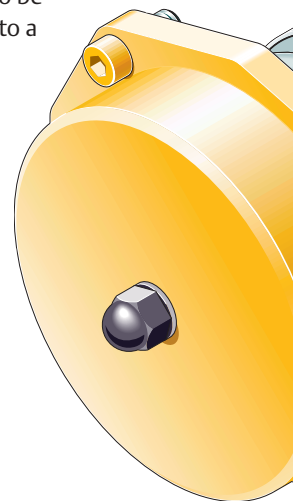

Limit stops

Limit stops are necessary where the precise adjustment of the valve's open position is required. These are standard on all actuators up to 1600 Nm. and optional on the two larger sizes. Actuators with double stroke adjustment are also available for those applications on high performance butterfly valves (closed position).

Standardisation

El-O-Matic actuators comply fully with all the relevant industry standards. Control interfaces for solenoid valves, switch boxes and positioners satisfy the NAMUR standard (VDI/VDE 3845). Valve mounting and drive dimensions are to ISO 5211 standard (option DIN 3337).

Inserts

Actuator sizes up to 1600 Nm. are fitted with drive inserts. This enables actuators to be directly mounted onto suitable valves and eliminates the need for a bracket and coupling type mounting kit. The increasing use of direct mounts significantly cuts the cost of the valve/actuator assembly. Standard actuators are fitted with square drive inserts in accordance with ISO 5211 (or DIN 3337), but a wide variety of other inserts are also available. Special inserts may have oversize or undersize squares, or with double-D or shaft key way forms. These can be supplied on factory built actuators or as loose items, drive inserts are easily replaceable at distributor or end user level.



inserts

Where direct mounts are not possible, for instance on valves with exposed gland packing, the use of inserts often simplifies the design of the mounting kit.

Long life span

El-O-Matic actuators have a patented 3-point guiding system, full synthetic bearings and a rack & pinion gearing. High precision gear cutting methods provide close tolerances and ensure minimum gear backlash, all of which guarantees virtually the longest working life of any actuator in the industry.

Application

The choice of actuator depends primarily on the valves' torque requirement, and with El-O-Matic you have the widest range possible, 12 basic model sizes covering a torque range from 12 to 4000 Nm.

But for optimum actuator sizing many factors may need consideration. El-O-Matic has all available relevant technical data on practically all the quarter-turn valve manufacturers in the world. This electronic database enables us to select just the right actuator for you, whatever the valve type: ball, butterfly or plug valve.

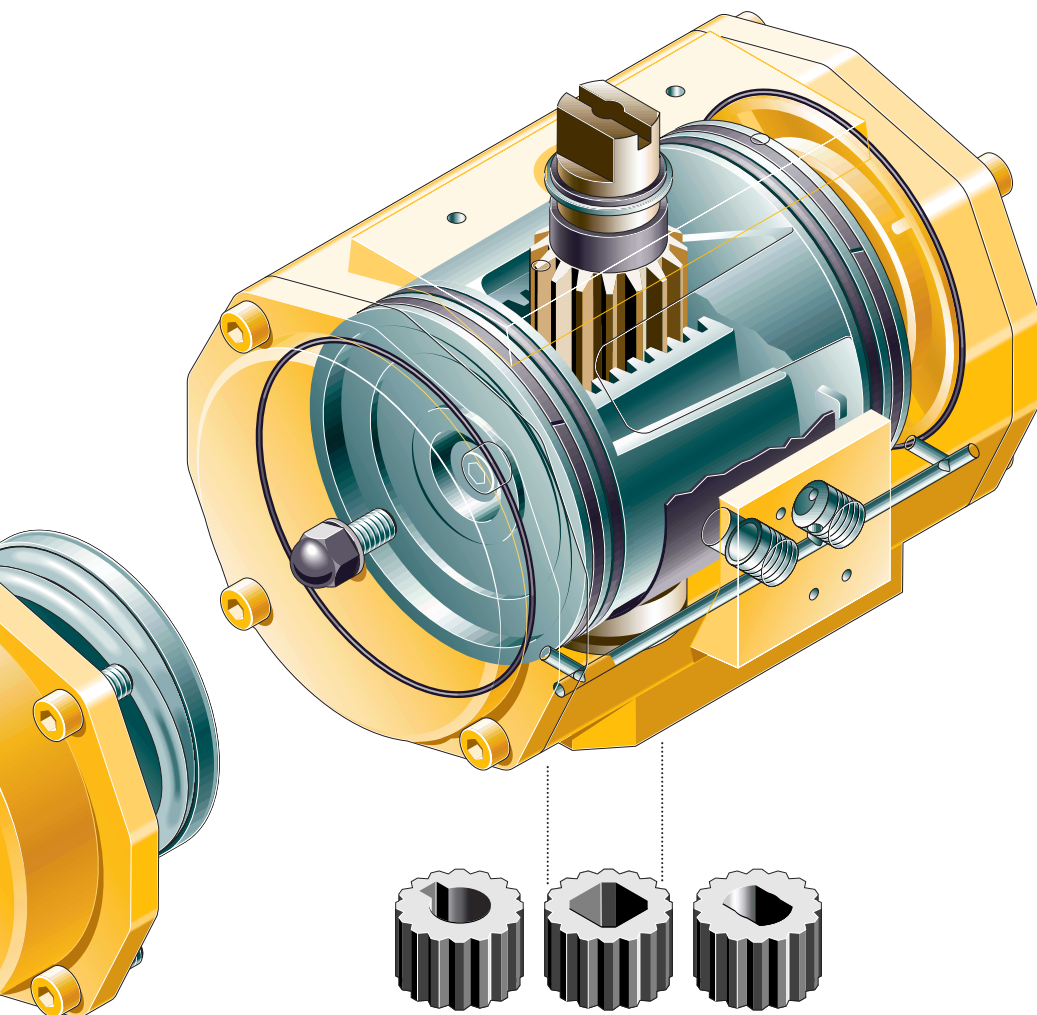

Pneumatic actuator

Special versions

Special actuators can be built to suit a wide variety of extreme applications: high temperature, low temperature, offshore, fire safe, with different operating media, etc.

Ask our technical specialists for more information about these special applications.



Pneumatic accessories



The basic actuator may be used to open and close the valve, but if more functionality is required then the actuators' specification can be extended by the addition of one or more of the available accessories. These can be used to make the actuator operate faster or slower or to provide position signalling feedback to the controller or to provide positional control. These are just a small sample of the countless additional possibilities provided by El-O-Matic pneumatic accessories. The range is extensive and is being added to all the time.

Position indication

For effective valve control, the controller needs to know the open/closed state of the valve. The El-O-Matic switch box range provides for every possible requirement for position indication. In addition to the basic versions described below, El-O-Matic supplies 2- or 3-wire proximity switches, reed switches and switches for specific explosion-safe applications.

HDN switch box

A heavy-duty (Aluminium alloy) switch box contains a pair of contact micro switches activated by two cams on a shaft driven by the actuator. These signal the full open and closed valve position. Both switches are independently adjustable and terminals are provided for the system's connection. The switch box is of generous proportions and has two electrical entries so that, with additional terminals, the connection to the actuator's solenoid valve may be back wired to provide the user with a single connection point.



HDN switch boxes can be supplied as waterproof executions (IP 67 to IEC 529) and explosion proof executions like EEx d or EEx i (ATEX certified), or Class I, Div. 1 group C, D. Class II, Div. 1 group E, F, G. (CSA certified).

LDN switch box

This switch box is suitable for utility applications or process applications under conditions that are less demanding. Functionality is similar to that of the HDN but with a lower level of waterproofing (IP 65) and limited explosion proof versions.



HDN (left) and LDN switch boxes.

Solenoid valve

Solenoid valves provide local open/close control by means of a remote powered electric signal. El-O-Matic supplies industry standard NAMUR solenoid valves for direct mounting on the air connection face of the actuator. These are spring return solenoid valves. On power failure automatically returning the actuator to a pre-set (normally closed) position. Solenoid valves are of the universal type and may be used on double acting or single acting actuators; the change is made by means of a reversible manifold plate. Standard solenoid valves are provided with a manual override control. As an option, speed control restricters are available fitted at the exhaust ports.



Specifications of standard switch boxes

		HDN	LDN
• Switches	Type	V3, mechanical	
	Voltage	250 V AC or DC	
	Contacts	normally open and normally closed, single-pole toggle switches	
	Current at 250 V AC	10 A	11 A
	Current at 250 V DC	1/4 A	1/4 A
	Current at 12 V DC	6 A	1 A
	Temperature	-20 °C to +80°C	-25 °C to +80°C
• Housing	Material	Aluminium alloy	Base: ABS (black) Cover: ABS (transp.)
	Protection category	IP 67 (IEC 529)	IP 65 (IEC 529)
	Finish	epoxy coating	
	Mounting	VDI/VDE 3845 NAMUR	

Pneumatic accessories



Manual Override control



Breather Block



Block & Vent valve

Specifications of solenoid valve

- Type: 5/2 - 3/2 (convertible)
- Pressure: 1 to 10 bar
- Lubrication: Not necessary
- Temperature: -20 to +60°C (depending on version)
- Voltage: 220 V AC/50 Hz or 24 V DC standard, other voltages on request
- Duty: Continuous
- Protection class: IP65, Explosion proof on request

Manual Override control

The El-O-Matic MO Series declutchable gear operators offer a simple and reliable method of local manual operation, this may be required during commissioning set up, as emergency control on air failure, or as a local control in the event of controller malfunction. As such when the hand wheel is clutched in, the valve is under local manual control and the remote control is "locked out".

Specifications of Manual Override gearbox

- Housing: Cast Aluminium
- Drive: Worm/worm wheel
- Worm wheel: Bronze
- Temperature: -20°C to +80°C
- Stroke limitation: +/- 5°
- Finish: 2-component polyurethane coating

Speed Control plate

This is used in combination with a NAMUR solenoid valve and serves to provide independent speed control of both the opening and closing strokes. The speed control plate can be used with both single and double acting actuators, but when used on single acting actuators, only the spring return stroke is regulated.

Breather Block

The breather block is used on single acting actuators and provides corrosion protection of the actuator spring chamber. It should be used on applications where the actuator is located in a corrosive atmosphere that would otherwise be sucked into the actuator during the spring stroke.

The breather block is fixed directly onto the actuators NAMUR air entry manifold and has a further NAMUR interface so that a suitable solenoid valve may be directly mounted, or for a tubing connection in the case of a remote solenoid valve.

The breather block has a built-in quick exhaust function to improve the spring stroke time. An optional speed control can be provided to regulate this closing time.

Block & Vent valve

This should be used on applications where on site servicing of the actuator is required and where the actuator needs to be isolated from the control system. It provides a local means of blocking the supply air from the actuator at the same time venting all compressed air from both chambers of the actuator. It may be used for double acting or spring return actuators. The valve block is fixed directly onto the NAMUR air entry manifold and has a further NAMUR interface so that a suitable solenoid valve may be directly mounted.

Specifications of Breather Block and Block & Vent valve

	Breather Block	Block & Vent valve
• housing	Aluminium alloy	Aluminium alloy
• Finish	Hard anodised	Anodised
		PTFE impregnated
• Pressure	1 to 10 bar	up to 10 bar
• Temperature	-20 to +80°C	-20 to +80°C
• Air inlet	G 1/4"	G 1/4"
• Air outlet	G 3/8"	G 3/8"
• Air flow (Kv)	air stroke: 0.8 m ³ /h spring stroke: 1.9 m ³ /h	0.8 m ³ /h 0.8 m ³ /h
• Media	air, dry or corrosion-free gas (not suitable for oxygen)	air, dry or corrosion-free gas (not suitable for oxygen)
• Option		lock

Pneumatic

accessories

BUS communication

El-O-Matic bus-communication products provide the possibility to control pneumatic actuators via various bus systems. Fieldbus interface cards are provided as options in our LDN and HDN. They can be supplied in water and dust proof versions as well as in explosion proof versions.

The LDN switchbox is available with ASI (actuator sensor interface), the HD box with ASI and Profibus-DP or PA. All have basic functionality of two-way communication, the fieldbus controller receiving input from the two position indicating switches (mechanically adjustable 0-90°), and an output to the solenoid valve(s) which may be to mono-stable or bi-stable. Bus wiring may be 2 wire or 4 wire depending on the system.



AS interface in LDN box

ASI application, weatherproof.

- Weatherproof housing IP65.
- LED indication of position, output and supply voltage.
- Output for a single, mono-stable solenoid (24 V DC, 2.6 W max.).
- Power supply for sensor and valve of AS interface.

AS interface in HD Box

ASI application, weatherproof or explosion proof.

- Weatherproof housing IP67.
- Explosion proof housing to ATEX II 2 GD EEx d IIC T6.
- LED indication of position and supply voltage.
- Output for a single, mono-stable solenoid (24 V DC, 2.6 W max.).
- Power supply for sensor and valve of AS interface.



AS interface in LDN box



AS interface in HD box

Pneumatic accessories



F20 electro-pneumatic positioner

Posiflex positioners

Positioners are instruments that play a vital part in the process. They must convert the incoming control signal quickly and efficiently and respond by regulating the valve to a precise position between 0 and 100%. The El-O-Matic "Posiflex" positioners are high quality, reliable instruments that form a strong link in modern process control systems.

POSIFLEX™

Posiflex positioners

The Posiflex range consists of 2 models, the pneumatic F10 and the electro-pneumatic F20. Both models are used in applications in which the pneumatic actuators must be positioned with a high degree of accuracy. The positioners are suitable for both single and double-acting. They can also be used for controlling other movements. All Posiflex positioners are robust, with housings of cast aluminium alloy with a finish of powder coating. They are highly resistant to external corrosion. The interior has a modular structure so that it can be simply adapted to your specific uses. The various accessories are described on this page.

Accessories

G 1 and G2 gauge blocks

- Type G1 is suitable for the Posiflex F10 and gives the actuator's operating pressure and the incoming instrument pressure.
- Type G2 is suitable for the Posiflex F20. It provides an indication of the output and incoming air pressure.

Position transmitters PTF20, PT2

These electronic position transmitters transmit a continuous 4 to 20 mA feedback signal, this reflects the mechanical position of the positioner. These position transmitters are also available in an intrinsically safe EEx i execution.

- The PTF20 is available as a "Plug-in" option for the F20 positioner.
- The PT2 is available as a "build in" module for F10 and F20 positioners.

Position indicators

- PNP, 3-wire inductive switches
- IS2, 2-wire inductive switches. This Intrinsically Safe variation may be used as part of an Intrinsically Safe system in an explosion hazardous area.
- S2, mechanical end of stroke V3 switches.
- POT, Potentiometer for a continuous resistive feedback signal of the valve position.

Features valve positioners

General

- Provides the ultimate in quick and accurate positioning.
- Suitable for single acting (spring return) and double acting actuators.
- High-grade aluminium alloy housing finished with an epoxy coating.
- Direct and reverse acting.
- Standard mounting to VDI/VDE 3845 (NAMUR).
- Modular structure, therefore easy expansion possibilities.
- Suitable for controlling rotary actuators and other devices.

F10

- Pneumatic positioner.
- Simple robust model.
- Only mechanical parts.
- External zero-setting.
- Hose down proof.

F20

- Electro-pneumatic positioner.
- Analogue electric signal (4-20 mA).
- Split-range and reverse-acting setting functions simply adjustable by jumpers.
- Intrinsically safe II 2 G EEx ib IIC T6 option.
- Enclosure IP65.



Gauge block



Electric Actuators & Accessories

High levels of performance are also required for electric valve actuators. The areas where these operate are often hostile to both the exterior and interior of the actuator. Further, because electric actuators are more frequently used in outdoor locations they are much more likely to be exposed to the continuous attack of environmental and chemical corrosion as well as the associated extreme fluctuations of temperature. In addition because of the remoteness of many applications it is even more vital that actuators continue reliably and at optimum performance for extended periods of time.

EL-O-MATIC®
INTERNATIONAL

Electric

actuators ELQ

Modular construction is used extensively in the the ELQ series electric actuators. Plug in modules are used for an extensive range of control options, these enable the basic actuator specification to be easily extended to that of fully-fledged control valve actuators. The basic actuator's digital electronics enable communication with the newest fieldbus systems as well as the traditional 4 – 20 mA analogue signals.

Further product innovations include the addition of drive inserts for easy mounting to a wide variety of valve types and an exclusive universal power supply connection. Here most AC/DC and three phase supplies may be directly connected to the actuator.

Modular options

These are plug-in modules and can be pre-installed at the factory, at distributor level or even installed in the field, all without special tools or any basic modification of the actuator. All these options may be installed on actuators with or without local control boxes.

- Speed control, with continuous and pulsating speed reduction.
- Local control box with soft-touch control buttons and protection class up to IP68.
- Position transmitter.
- Valve-positioner, with automatic initialisation and intelligent digital control.
- Additional switches.

Features

- **Low power consumption.**
Saves power and cables, and therefore costs.
- **100% duty rating.**
Can be used for all applications, and protects against the motor overheating.
- **100% torque over the entire stroke.**
To cover all applications, even those valves with complex torque patterns.
- **3,600 starts per hour.**
Can be used for all modulating applications.
- **Constant engaged manual override.**
Safety non-rotating hand wheel but constantly available for manual emergency control.
- **Compact, balanced design.**
Reduces costs for pipeline support, prevents stresses in the pipe work and eliminates side loads on the valve spindle.

Operating principle

The basic version of the ELQ is intended for simple open/close applications.

For more sophisticated applications a large variety of options provides the solution. These



options (insert modules) are easy to install on the motherboard without any special tools. The external control signals and the signals for the various insert modules are passed to the electrical motherboard via the terminal compartment, the 'serving hatch' of the actuator. The terminal block too is a plug-in item, so that when interchanging actuators the terminal block complete with its wiring may be reconnected to another ELQ.



High-ratio gearing

Terminal compartment



Removable terminal block for the supply voltage

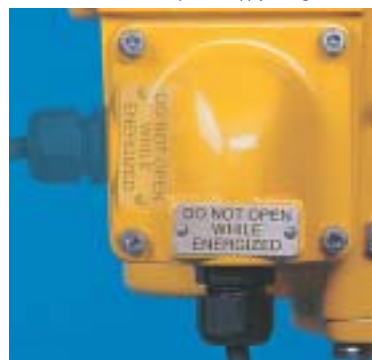

Exchangeable insert



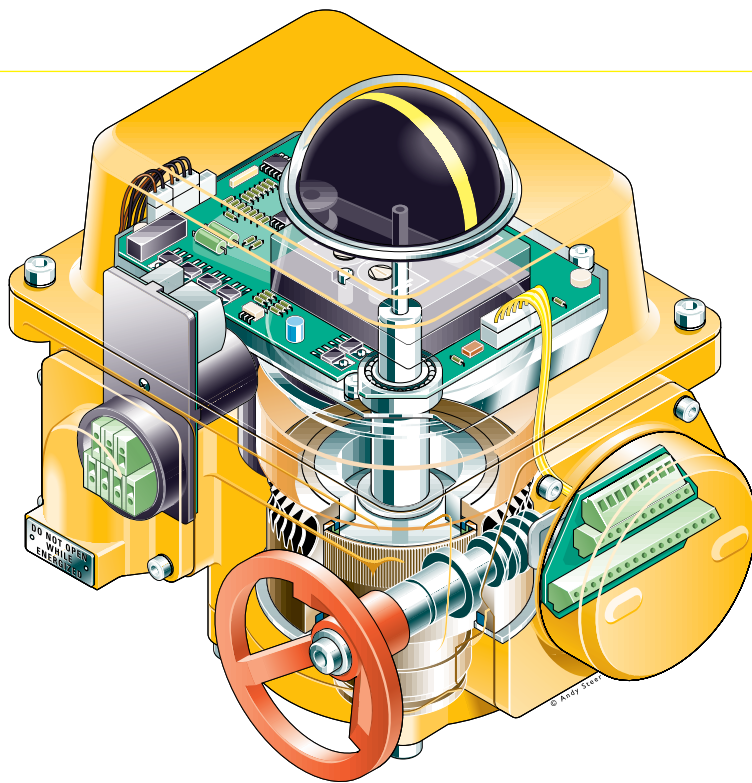

the ELQ with its many possibilities may also be more suitable for applications requiring more complex communication between control room and actuator.

Standardisation

The ELQ is produced in accordance with the quality standard ISO 9001. The actuator is also in compliance with the following industry standards:

- Water and dust proof IP67 (optionally IP68) to IEC 529 and NEMA 4 to ICS 6-110.15.
- Explosion proof EEx d IIB T4 to EN50014/EN50018 and NEMA 7, 9 to ICS 6-110.24.
- Valve mounting to ISO 5211 and DIN 3337

The ELQ is provided with an efficient, high-ratio reduction gear system. This provides the benefits of low power consumption, low noise emission and minimum backlash in the gear drive. All with an extremely light and compact unit.

available relevant technical data on practically all quarter-turn valve manufacturers in the world. This electronic database enables us to select the right actuator for you, whatever valve type: ball, butterfly or plug valve.

Options

Due to their modular construction, ELQ options can be easily installed. The options are:

- Extra limit switches
- Position transmitter
- Intelligent positioner
- Status information module
- Communication cards
- Speed control
- Local control unit

Torque and sizing

The ELQ range comprises five different size types: ELQ100, ELQ200, ELQ300, ELQ500 and ELQ800.

The choice of actuator depends primarily on the valves' torque requirement, but for optimum actuator sizing many factors need consideration. El-O-Matic has all

Application

For some applications electric actuators are preferred to pneumatic. For instance, where there are large distances between actuated valves, in this case electric cabling is often less expensive than installing a compressed air system. Electric actuators such as



Electric

actuators ELQ

BUS communication

El-O-Matic has developed various options for the ELQ actuators in order to allow for control via the various bus systems. Communication with these bus systems is handled by means of electronics partially incorporated in an expansion box mounted on the side of the ELQ. Because the ELQ uses digital electronics for basic control within the actuator it can easily handle bus type communications of most types from the relatively simple systems, such as ASI (actuator sensor interface) to the more complex systems such as Fieldbus Foundation™, Profibus®-DP and Profibus®-PA.

Q-CFF/Q-CDPS/Q-CPAS option

With this ELQ option, El-O-Matic provides an electric actuator with Fieldbus Foundation™ or Profibus®-DP/PA digital field-bus communication. Using these field-bus options, the input and output signals of the actuator can be sent via a two-wire connection and connected to the control system via a fieldbus network. For Fieldbus Foundation™ and Profibus®-DP or PA, three version levels are available for 'open/close' and 'modulating' applications.

'Open/close' versions:

- A maximum of four digital outputs (DO) and two analogue inputs (AI) available.
- Possibility to activate or deactivate the bus communication

and open/close the actuator by conventional means.

- Standard feedback of stroke end position, signals for opening/closing, over torque or motor-switch faults.
- Feedback of actuator temperature, run torque, maximum torque, heater element on/off, stroke position and when the local control unit is used.
- Read-out possibility of various identification items.

Modulating versions:

In addition versions fitted with the modulating positioner have the following reset functions:

- Remote initialisation of actuator via bus.
- Maximum of three analog inputs (AI) available.

- Standard digital adjustable Sensitivity/Deadband.

- Digital adjustments possible for zero range, high and low signal, action, response curve: Linear, equal percentage or quick opening.
- Custom curve: the ability to modify the equal percentage or quick opening curves.
- 20-point curve: The response curve can be freely modified based on a 20-point co-ordinate grid.

Q-ASI option

This ELQ option makes it possible to open and close the actuator by means of the 2-wire AS interface bus system and get feedback from the stroke end positions.

- Discrete bus communication.
- No external supply voltage necessary for I/O cards.
- Explosion proof versions applicable in zones 1 and 2.
- LED indication of position and supply voltage.



Electric actuators EL



As market leader in actuators, we realise that the consistent high quality of our products is of crucial importance to your production process. That's why our development activities focus on quality. You'll find this reflected by the performance of our actuators, and in our choice of such materials as high quality aluminium alloys, stainless steel and bronze. El-O-Matic electric actuators are reliable quality products, which can be relied on to perform faultlessly no matter how demanding the circumstances.

Features

Standard versions are provided with mechanical end stops, limit switches for open/close indication and anti-condensation heater. Corrosion resistant materials used throughout: Aluminium housing, stainless steel fastenings and hard-bronze gear transmission.

Also:

- Can be applied to all ball, plug and butterfly valves.
- Low-noise, smooth running by the use of high ratio worm and wheel reduction.
- Compact construction and lightweight due to the use of high-grade aluminium alloys
- Corrosion protected by the use of the external coating (2-component polyurethane).
- Wide range of voltage options.

- Self-locking reduction gear with minimum backlash in the transmission.
- Visual position indicator.
- Mountings in accordance with the ISO 5211 or DIN 3337 standard.

ELS, EL and ELD electric actuator series

Our range of electrical actuators comprises the ELS, EL and ELD series. The series covers the torque range from 18 to 2500 Nm. The ELS series is an economic choice for application on fittings with a small passage area. The ELD series is designed for heavier applications and is provided with a declutchable manual override emergency control.

Standards

The ELS, EL and ELD series are produced in accordance with the quality standard ISO 9001. The actuators, depending on model size, are also in compliance with the following industry standards:

- ISO 5211, EN 55014
- DIN 3337, EN 50082-2
- EN 50014, EN 50018, EN 50093
- EN 60204, EN 60529

Operating principle

All actuators in these series are totally self enclosed and have thermal switches in the motor windings to prevent motors from overheating. Standardised connection flanges are used for simple installation on all quarter turn valves, such as ball, plug and butterfly valves.

ELS actuators are the economic choice for small valves in the torque range of 18 to 25 Nm. The basic AC or DC motors provide torque by means of a set of spur reduction gears.

EL actuators cover the middle range of torques from 55 to 800 Nm. They have worm/worm wheel reduction gearing and hand wheel manual override. This is directly engaged for hand operation and is disengaged on



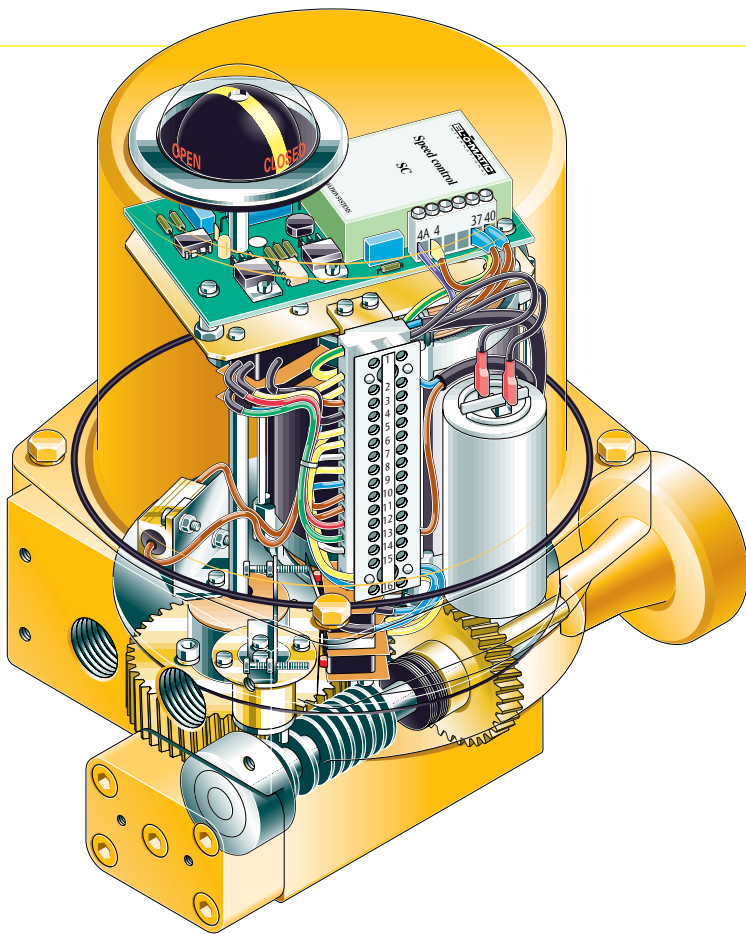

release, hence is non-rotating when under motor control. Torque switches are included to provide mechanical protection for the actuator drive and that of the driven valve components. The worm/worm wheel reduction gearing is self-locking and is exceptionally smooth and quiet in operation.

ELD actuators are designed for heavier applications and have torques from 1200 to 2500 Nm. They are basically similar to the EL actuators (above) but in addition are provided with a de-clutch manual override.

Application

Remote operated valves mean ease of operation, increased efficiency, better control of the system and therefore an increased life span of the installation. Where there is no compressed air available, the choice for electric actuators is an obvious one, but for

new installations electric actuators can have a cost advantage. The basic cost of compressed air is certainly more than that of electric power, and electrical cabling is more flexible and less expensive to install than a compressed air network.

Electric actuators are also suitable for applications requiring a high torque: the standard version of the EL series covers torques up to 2500 Nm.

So which actuator should you use? El-O-Matic has all available relevant technical data on practically all quarter-turn valve manufacturers in the world. This electronic database enables us to select the right actuator for you, whatever valve type: Ball, butterfly or plug valve.

Special versions

- Low temperature versions.
- Explosion proof version.

Options

El-O-Matic EL series electric actuators are not restricted to open/close applications, with the addition of one or more of the available kit options the requirements for fully-fledged control units can often be met. For instance in many cases the addition of a positioner will enable the actuator to be used for sophisticated control applications. Below is a brief summary of the available options:

- Extra switches.
- Speed controllers.
- Potentiometers.
- Position transmitters.
- Positioners.
- Local control station.

These options may be added to factory built units, or supplied in kit form. When supplied as kits all parts are included together with a simple to follow installation sheet.

We would be happy to advise you concerning your particular requirements.





Torque & technical data

EL-O-MATIC®
INTERNATIONAL

Pneumatic actuators

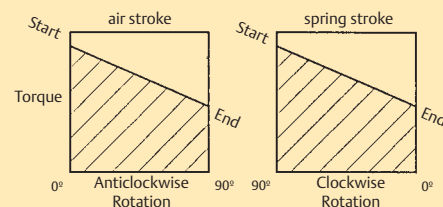

Torque diagram with single acting actuators

Torques in Nm

Single Acting

Spring set no. Actuator Type	Air stroke (Nm, pressure in bar)																		Spring stroke (Nm)	
	3		3.5		4		4.5		5		5.5		6		7		start	end		
	start	end	start	end	start	end	start	end	start	end	start	end	start	end	start	end	start	end		
ES12	2	-	3.7	1.0	5.0	2.3	6.4	3.6	7.7	4.9	9.0	6.2	10.3	7.5	12.9	10.1	7.2	4.6		
ES25	3	7	9	5	11	7	14	9	16	12	19	14	21	17	26	21	11	7		
	4	-	-	-	-	-	9	3	11	5	14	8	16	10	19	13	23	17		
	5	-	-	-	-	-	-	-	-	-	11	4	14	6	16	8	21	13		
	6	-	-	-	-	-	-	-	-	-	-	-	11	2	14	4	18	9		
ES40	3	12	17	8	21	13	26	17	31	22	35	27	40	31	49	40	20	12		
	4	-	-	-	-	17	5	21	10	26	14	30	19	35	23	44	32	26	17	
	5	-	-	-	-	-	-	-	21	7	26	11	30	16	39	25	33	21		
	6	-	-	-	-	-	-	-	-	7	21	4	25	8	34	17	40	25		
ES65	3	18	25	11	32	18	39	25	46	32	52	39	59	46	73	60	32	20		
	4	-	-	-	-	24	6	31	13	38	20	45	27	52	34	66	48	42	26	
	5	-	-	-	-	-	-	-	-	30	8	37	15	44	22	58	36	53	33	
	6	-	-	-	-	-	-	-	-	-	30	3	37	10	50	23	63	40		
ES100	3	29	39	20	49	30	59	41	70	51	80	61	90	71	110	91	44	27		
	4	-	-	-	-	39	14	49	24	59	34	69	44	80	54	100	75	58	37	
	5	-	-	-	-	-	-	-	-	49	17	59	27	69	38	89	58	73	46	
	6	-	-	-	-	-	-	-	-	-	48	11	59	21	79	41	88	55		
ES200	3	61	84	42	106	64	129	86	151	109	173	131	196	153	240	198	98	61		
	4	-	-	-	-	83	26	105	49	127	71	150	93	172	116	217	160	131	82	
	5	-	-	-	-	-	-	-	-	104	33	126	56	149	78	193	123	164	102	
	6	-	-	-	-	-	-	-	-	-	103	18	125	41	170	85	196	123		
ES350	3	101	140	68	179	107	217	146	256	185	295	224	334	263	412	340	174	112		
	4	-	-	-	-	136	41	175	80	214	118	252	157	291	196	369	274	232	149	
	5	-	-	-	-	-	-	-	-	171	52	210	91	249	130	326	207	289	186	
	6	-	-	-	-	-	-	-	-	-	-	-	-	206	63	283	141	347	223	
ES600	3	179	245	120	311	186	377	252	443	318	509	384	575	450	707	582	292	183		
	4	-	-	-	-	240	74	306	140	372	206	438	272	504	338	636	470	389	245	
	5	-	-	-	-	-	-	-	-	302	94	368	160	434	226	566	358	487	306	
	6	-	-	-	-	-	-	-	-	-	298	48	364	114	496	246	584	367		
ES950	3	272	371	181	469	279	568	378	666	476	765	575	863	673	1060	870	434	269		
	4	-	-	268	14	366	113	465	211	563	310	662	408	760	507	957	704	579	359	
	5	-	-	-	-	-	-	-	-	460	143	559	242	657	340	854	537	724	448	
	6	-	-	-	-	-	-	-	-	-	456	75	554	174	751	371	869	538		
ES1600	3	445	608	307	771	470	934	633	1097	796	1260	959	1423	1121	1748	1447	711	449		
	4	-	-	-	-	599	198	762	361	925	523	1088	686	1251	849	1577	1175	947	598	
	5	-	-	-	-	-	-	-	-	753	251	916	414	1079	577	1405	903	1184	748	
	6	-	-	-	-	-	-	-	-	-	744	142	907	305	1233	630	1421	897		
PS2500	8	712	958	566	1203	811	1449	1057	1694	1302	1940	1548	2186	1794	2677	2285	1057	663		
	10	-	774	284	1019	529	1265	775	1510	1020	1756	1266	2001	1511	2492	2002	1321	829		
	12	-	-	-	835	247	1080	492	1326	738	1572	984	1817	1229	2308	1720	1585	995		
	14	-	-	-	-	-	896	210	1142	456	1387	701	1633	947	2124	1438	1849	1160		
PS4000	8	1213	1629	968	2045	1384	2462	1800	2878	2216	3294	2633	3710	3049	4543	3882	1783	1119		
	10	-	1318	491	1734	908	2151	1324	2567	1740	2983	2157	3400	2573	4232	3405	2229	1399		
	12	-	-	-	1423	431	1840	848	2256	1264	2672	1680	3089	2097	3921	2929	2674	1679		
	14	-	-	-	-	-	1529	372	1945	788	2362	1204	2778	1620	3610	2453	3120	1958		

Double Acting

Actuator	Pressure (bar)										
	2	3	3.5	4	4.5	5	5.5	6	6.5	7	8
ED12	4.8	7.3	8.5	9.7	10.9	12.2	13.4	14.6	15.9	17.1	19.6
ED25	9	13	16	18	20	23	25	27	29	32	36
ED40	17	25	29	34	38	42	47	51	55	59	68
ED65	25	38	45	51	58	64	71	78	84	91	104
ED100	37	57	66	76	86	95	105	114	124	134	153
ED200	82	124	146	167	188	209	230	251	272	293	335
ED350	143	216	253	290	326	363	400	436	473	510	583
ED600	243	368	430	492	554	617	679	741	804	866	991
ED950	363	549	642	735	828	921	1014	1107	1200	1293	1479
ED1600	600	907	1061	1214	1368	1522	1676	1829	1983	2137	2444
PD2500	958	1449	1694	1940	2186	2431	2677	2922	3168	3413	3904
PD4000	1624	2456	2872	3289	3705	4121	4538	4954	5370	5786	6619

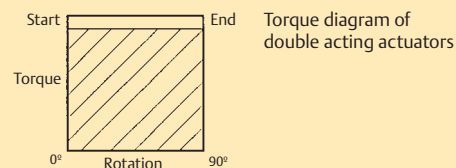

Torque diagram of double acting actuators

Dimensions and technical data

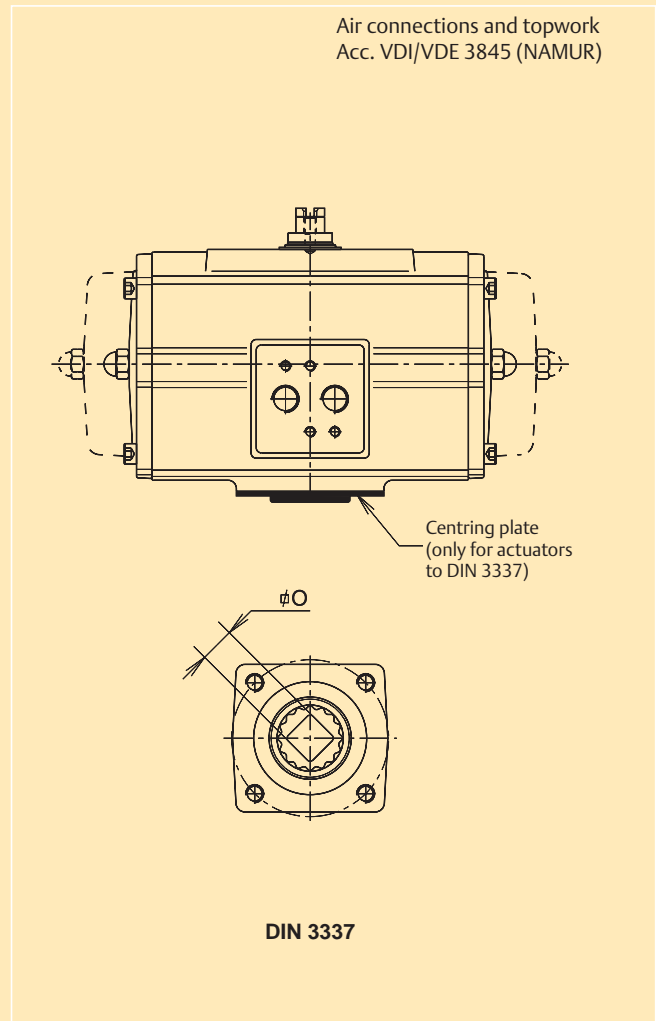
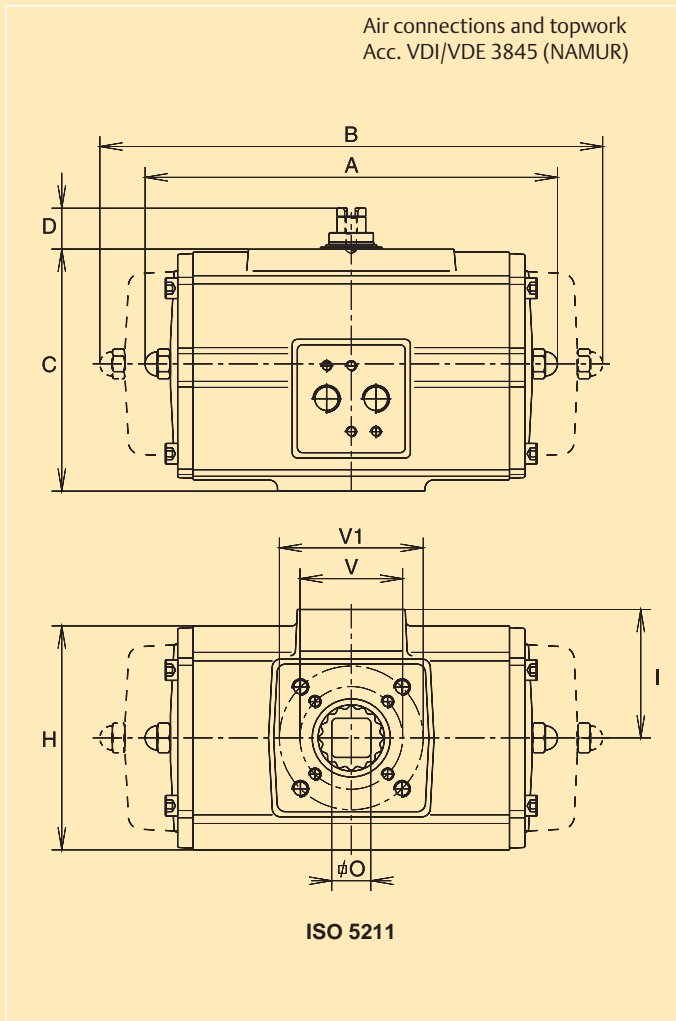

Technical data

Actuator type		E12	E25	E40	E65	E100	E200	E350	E600	E950	E1600	P2500	P4000	
Bore	mm.	46	56	70	80	91	110	145	175	200	230	300	325	
Stroke	mm.	12.6	15.7	18.8	22	25.1	37.7	37.7	44	50.3	62.8	56.5	81.7	
Weight:	DA	kg.	0.61	1.3	1.8	2.4	3.1	5.8	10.4	19.4	26.4	42.7	56.8	86.6
	SR	kg.	0.67	1.7	2.4	3.6	4.6	9.1	16.9	27.6	38.6	65.8	88.2	131.8
Operating time	sec.	0.4	0.5	0.7	1.1	1.2	2.3	3.6	4.5	5.4	6.9	7	12	
Air consumption	port A	stroke	0.05	0.1	0.16	0.33	0.35	0.8	1.8	2.9	4.7	7.3	8	13.5
at 1 atm (litres)	port B	stroke	0.06	0.11	0.22	0.36	0.49	1	1.9	3.1	4.9	8.0	9.3	17.5

Dimensions (mm.)

	A DA	103	159	180	199	221	283	305	387	424	516	378	502
	B SR	118	172	204	249	267	360	387	477	517	637	570	834
	C	60	80	93	105	118	143	181	220	259	297	356	380
	D	20	20	20	20	20	20	20	30	30	30	30	30
	H	60	74	86	98	108	128	173	207	231	265	350	380
	I	33	46	53	58	63	73	95	113	126	142	183	200
ISO 5211	O	9	11	14	14	19	22	27	27	36	46	46	55
	V1/V2	42	36/50	50/70	50/70	50/70	70/102	70/102	102/125	102/140	165/254	165/254	165/254
	W1/	M6	M5/	M6/	M6/	M6/	M8/	M8/	M10/	M10/	M20/	M20/	M20/
	W2		M6	M8	M8	M8	M10	M10	M12	M16	4xM16	4xM16	8xM16
DIN 3337	O	9	11	14	14	17	22	22	27	36	46	46	55
	V	42	50	50	50	70	102	102	125	140	165	165	254
	W	M6	M6	M6	M6	M8	M10	M10	M12	M16	M20	M20	M16

Electric actuators ELQ

Dimensions and technical data

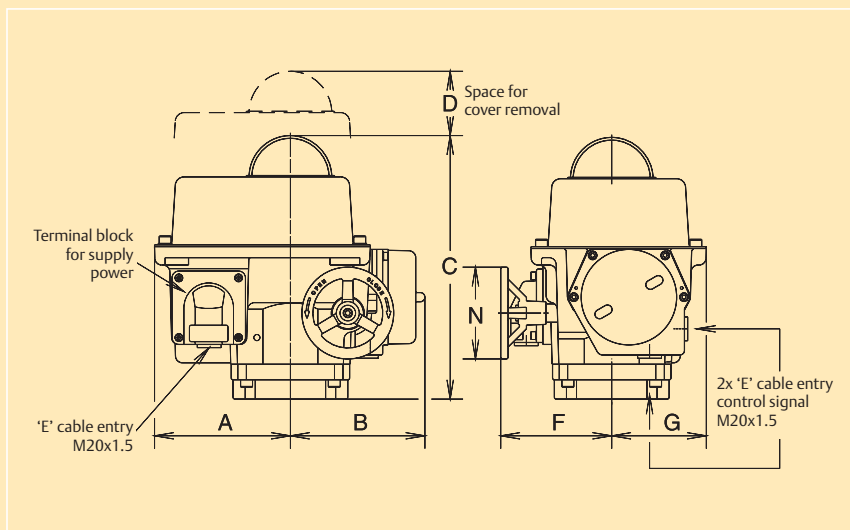

Mounting flange ISO 5211

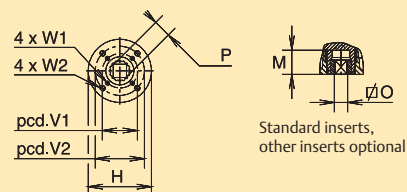

Mounting flange DIN 3337

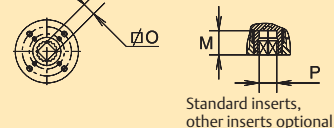

Dimensions of local control unit WP version

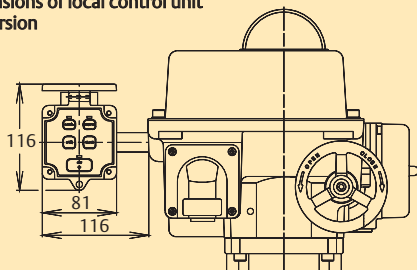

Dimensions of local control unit Explosion proof version

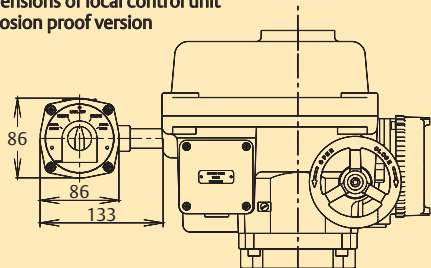

Dimensions of Option Box with:

- Fieldbus Foundation™
- Profibus DP
- AS-Interface
- Relay Box

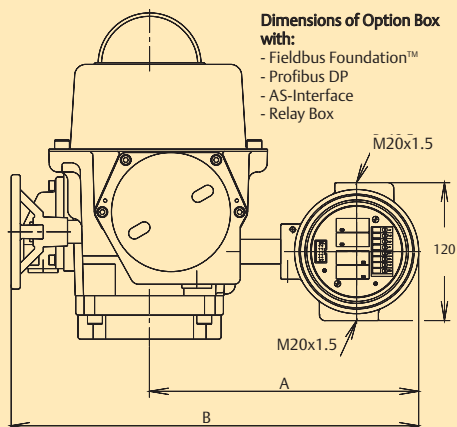

Diam. in mm	ELQ 100	ELQ 200	ELQ 300	ELQ 500	ELQ 800
A	205	205	205	258	258
B	323	361	361	477	514

Technical data

Actuator type		ELQ100	ELQ200	ELQ300	ELQ500	ELQ800
Max. torque (Nm.)	Break/Run	100	200	300	500	800
Speed./90° (Sec.)	max. load	10	14	18	22	36
	no load	6	8	13	17	28
Power (A)	115VAC	1	1	1	1.7	1.7
	230VAC	0.5	0.5	0.5	0.9	0.9
Max.	400VAC	0.3	0.3	0.3	0.5	0.5
	24V DC	4.1	4.3	4.0	5.3	5.1
Power (W) rated		98	102	96	130	125
Weight (Kg)		13	14	14.5	28	30

Dimensions (mm.)

A	148	148	148	182	182
B	147	147	147	187	187
C	287	287	287	335	335
D	100	100	100	100	100
"E"	M20	M20	M20	M20	M20
F	118	156	156	219	256
G	103	103	103	132	132
H	125	125	125	175	175
M	50	50	50	60	60
N	100	180	180	300	400

ISO 5211

O	19	19	22	27	36
P	25.2	25.2	28.2	36.2	48.2

DIN 3337

O	17	22	22	27	36
P	25.2	25.2	28.2	36.2	48.2

V1	70	70	70	102	102
V2	102	102	102	140	140

W1	M8x13	M8x13	M8x13	M10x16	M10x16
W2	M10x16	M10x16	M10x16	M16x25	M16x25

Electric

actuators ELS, EL and ELD

Dimensions and technical data

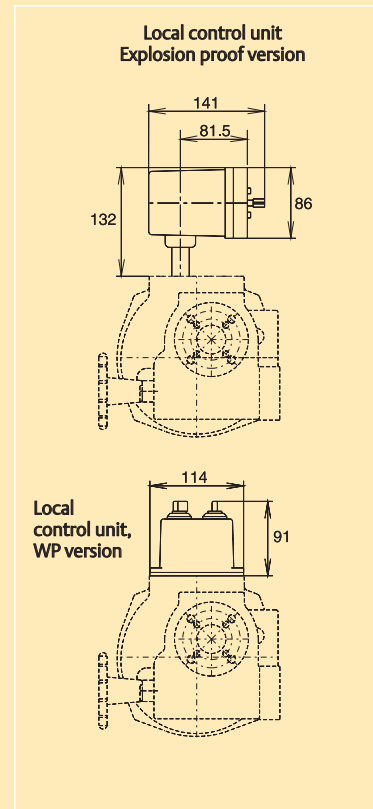
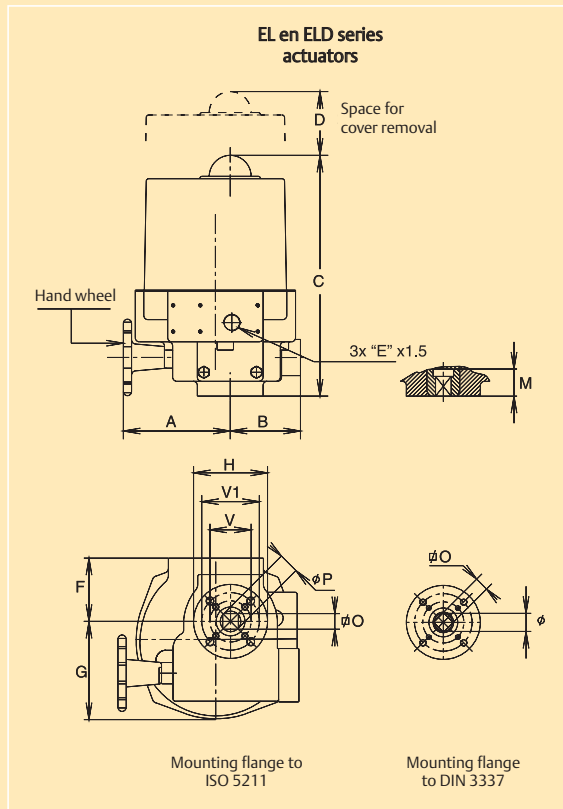
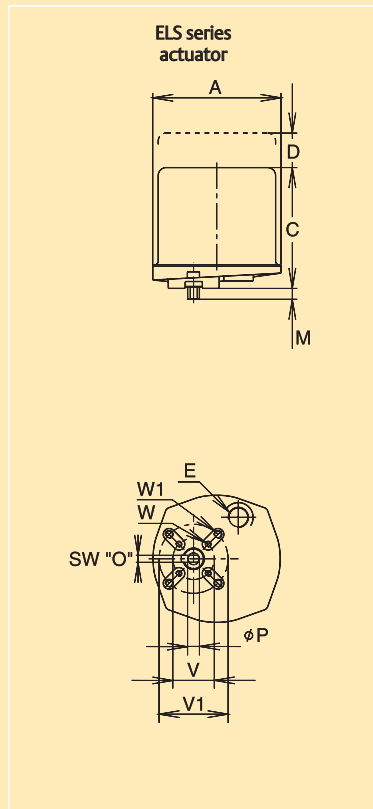

Actuator type		ELS18	ELS25	EL55	EL100	EL150	EL200	EL350	EL500	EL800	ELD1200	ELD1600	ELD2500
Torque (Nm)	Break	18	25	55	100	150	200	350	500	800	1200	1600	2500
	Run	14	20	20	35	53	70	123	175	280	420	560	875
Speed (Sec.)	50Hz	6.5	9.5	6	7	9	13	23	25.5	25.5	25.5	25.5	28
	60Hz	5.5	7.5	5	6	7.5	11.5	18	21.5	21.5	21.5	21.5	22.5
Current (A) (Max.)	110V AC	0.55	0.6	1.1	2.9	2.9	2.9	2.9	2.9	4.5	14	14	58
	220V AC	0.1	0.3	0.6	1.0	1.7	1.7	1.7	1.7	2.3	7	7	27
	380V AC	-	-	0.4	0.7	0.7	0.7	0.7	0.7	0.9	2.8	2.8	9
	24V DC	0.8	0.51	5	8	8	8	8	8	12	-	-	-
Power (W)	110V AC	45	25	100	225	225	225	225	225	315	535	535	720
	220V AC	40	65	72	200	200	200	200	200	305	450	450	792
	24V DC	4.8	2.4	45	118	118	118	118	118	-	-	-	-
Weight (Kg.)		2.2	2.8	6	11	11	16.5	17	25.5	26	37	37	75
Duty rating		50%	50%	30%	30%	30%	30%	30%	30%	30%	30%	30%	30%

Dimensions (mm.)

A	130	157	130	135	135	170	170	195	195	263	263	320
B	-	-	60	82	82	109	109	128	128	128	128	220
C	122.5	135	255	292	292	315	315	318	356	378	378	485
D	85	100	145	165	165	165	165	165	190	110	110	130
"E"	M20	M20	M20	M20	M20	M20	M20	M20	M20	M20	M20	M25
F	-	-	70	77	77	96	96	123	123	123	123	160
G	-	-	95	120	120	140.5	140.5	166	166	261	261	232
H	-	-	90	90	90	125	125	150	150	176	176	210
M	11.2	13	27.5	33	33	33	33	48	48	89	89	76

ISO 5211	O	7	10	14	19	19	19	19	27	27	36	36	46
	P	11	12	18	25	25	25	25	36	36	48	48	60

DIN 3337	O	7	10	14	17	17	17	17	27	27	36	36	46
	P	11	12	18	22	22	22	22	36	36	48	48	60

V1	42	50	50	50	50	70	70	102	125	140	140	165
V2	-	70	70	70	70	102	102	-	-	-	-	-
W1	M6x9	M6x12	M6x12	M6x12	M6x12	M8x15	M8x15	M10x18	M12x20	M16x25	M16x25	M20x32
W2	-	M8x15	M8x15	M8x15	M8x15	M10x18	M10x18	-	-	-	-	-

EUROPE, MIDDLE EAST & AFRICA

- P.O. Box 223
7550 AE Hengelo (O)
Asveldweg 11
7556 BT Hengelo (O)
Holland
T +31 74 256 10 10
F +31 74 291 09 38
E Info.ValveAutomation-EMA
@EmersonProcess.com

GERMANY

- Postfach 500155
D-47870 Willich
Siemensring 112
D-47877 Willich
T +49 2154 499660
F +49 2154 499 66 13
E Info.ValveAutomation-BRD
@EmersonProcess.com

UNITED KINGDOM

- 6 Bracken Hill
South West Industrial Estate
Peterlee
Co Durham SR8 2LS
T +44 (0) 191 5180020
F +44 (0) 191 5180032
E Info.ValveAutomation-UK
@EmersonProcess.com

www.El-O-Matic.com

NORTH & SOUTH AMERICA

- 9009 King Palm Drive
Tampa
Florida
33619
U.S.A.
T +1 813 630 2255
F +1 281 630 9449
E Info.ValveAutomation-USA
@EmersonProcess.com

SOUTH AFRICA

- P.O. Box
Isando
1600
2 Monteer Road
Isando
South Africa
T +27 11 974 3336
F +27 11 974 7005
E Info.ValveAutomation-SA
@EmersonProcess.com

SINGAPORE

- Emerson Process Management,
Valve Automation division
19 Kian Teck Crescent
Singapore 628885
Tel: +(65) 6262-4515
Fax: +(65) 6268-0028
E Info.ValveAutomation-AP
@EmersonProcess.com

Your distributor :

All Rights Reserved.
Important: We reserve the right to modify or improve the designs or specifications of the products mentioned in this manual at any time without notice. Emerson Process Management does not assume responsibility for the selection, use or maintenance of any product. Responsibility for proper selection, use and maintenance of any Emerson Process Management product remains solely with the purchaser.
EL-O-MATIC® is a registered trademark of EL-O-MATIC B.V.
PosiFlex™ is a trademark of EL-O-MATIC B.V.
PROFIBUS® is a registered trademark of PROFIBUS International.
Foundation Fieldbus® is a registered trademark of Fieldbus Foundation.
©2006 Emerson

