



M+S HYDRAULIC



HYDROSTATIC STEERING UNITS & ACCESSORIES



TYPE HKU
HKUS
UVM
XY

HYDROSTATIC STEERING UNITS AND ACCESSORIES

CONTENTS

	Page
Hydrostatic Steering Units Type XY.../1, 2.....	3
Hydrostatic Steering Units Type HKU.../3, 4.....	5
Hydrostatic Steering Units Type HKU.../7.....	6
Hydrostatic Steering Units Type HKU.../4PB	8
Hydrostatic Steering Units Type HKUQ.../4	10
Hydrostatic Steering Units Type HKUS.../3, 4, 8.....	12
Hydrostatic Steering Units Type HKUS.../5(T)(E)(TE).....	15
Valve Blocks For HKU And XY Type BKH.....	20
Priority Valves For HKUS.../5... Type PR.....	22
Priority Valves For HKUS.../5... Type PRT.../160.....	25
Torque Amplifiers Type UVM.....	27
Steering Columns Type KK.....	29
General Application And Specification Information.....	34

HYDROSTATIC STEERING UNITS TYPE XY.../1



The M+S Hydraulic Hydrostatic Steering units are used in low-speed vehicles which driving speed does not exceed 60 km/h - such as: building machines, fork-lift trucks, harvesting machines, off-highway equipment and others. These hydraulic units amplify the torque to the steering wheels, with no need of hard mechanical connection.

The XY hydrostatic steering unit incorporates an axially displaced tracing valve and a metering pump in one housing. The working liquid is supplied by a separate pump and then is directed by the metering pump to the steering cylinders.

The XY steering unit is manufactured with built-in check valves, and there is an option for a built-in relief valve in the inlet.

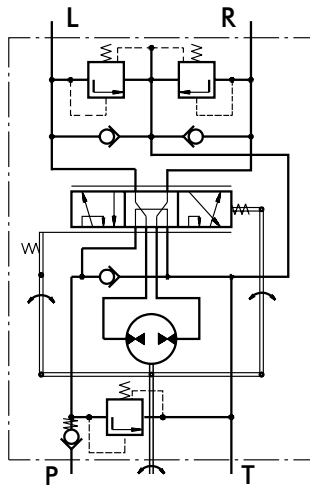

"Open Center - Load Reaction"
With Built-in Valves
Version 1 - XY.../1

SPECIFICATION DATA

Parameters	Type		
	XY 85.../1	XY 120.../1	XY 145.../1
Displacement [cm ³ /rev]	84	120	144
Rated Flow* [l/min]	9	12	15
Rated Pressure [bar]	150		
Relief Valve Pressure Settings** [bar]	80	100	125
Shock Valves Pressure Setting*** [bar]	200		
Max.Cont.Pressure in Line T - P _T [bar]	20		
Max.Torque at Servoamplifying [Nm]	7,5 (by P _T max)		
Max.Torque w/o Servoamplifying [Nm]	125		
Weight, avg. [kg]	6,4	6,6	6,8
Dimension A [mm]	136,3	141,5	144,5

* Rated Flow at 100 RPM.

** Pressure Settings are at Rated Flow (as in the table) and viscosity 21 mm²/s (50° C).

***Pressure Settings are at flow rate of 4 l/min and viscosity 21 mm²/s (50° C).

DIMENSIONS AND MOUNTING DATA

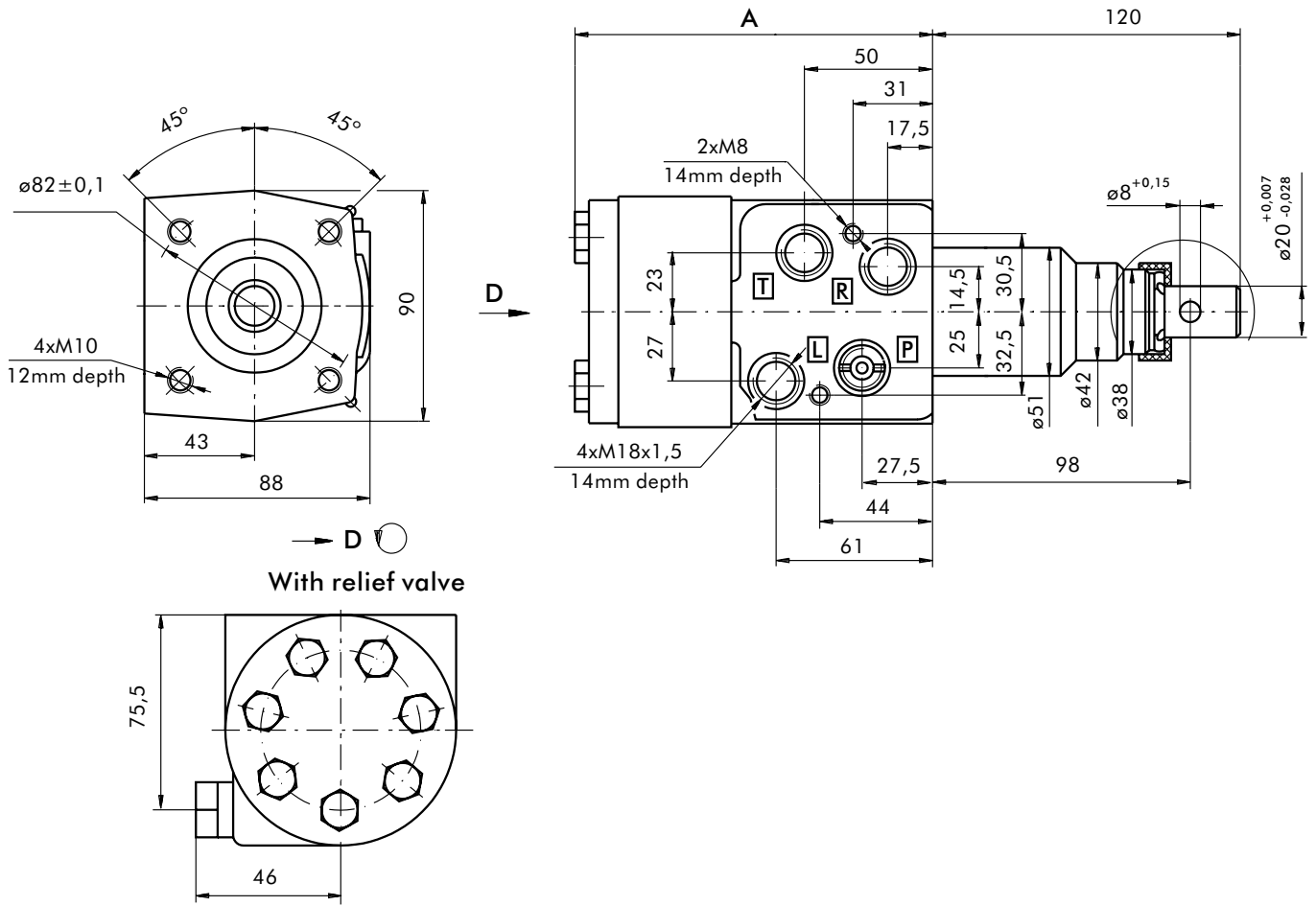

With relief valve

ORDER CODE

	1	2	3	4	5
XY		-	/	1	

Pos.1 - Displacement code

- 85** - 84 [cm³/rev]
- 120** - 120 [cm³/rev]
- 145** - 144 [cm³/rev]

Pos.2 - Relief Valve Pressure Settings

- 8** - 80 bar
- 10** - 100 bar
- 12,5** - 125 bar
- 15** - 150 bar
- 0** - without Relief Valve

Pos.3 - Versions

- 1** - Version 1 "Open Center - Load Reaction"

Pos.4 - Option (Paint)*

- omit - No Paint
- P** - Painted
- PC** - Corrosion Protected Paint

Pos.5 - Design Series

- omit - Factory specified

NOTES:

* Colour at customer's request.
 The steering units are mangano-phosphatized as standard.

HYDROSTATIC STEERING UNITS TYPE HKU.../3, 4



The newly designed HKU steering units, with radial distribution, incorporate two rotary tracing valves in the housing, which turn on the metering pump.

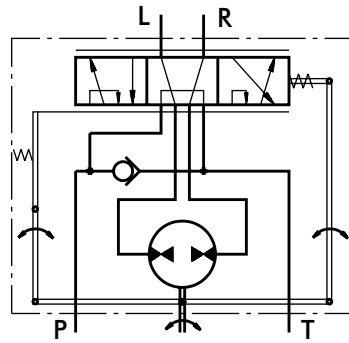

"Open Center - Load Reaction"
Version 3 - HKU.../3

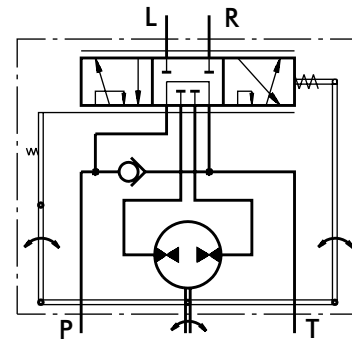

"Open Center - Non Load Reaction"
Version 4 - HKU.../4

SPECIFICATION DATA

Parameters	Type															
	HKU 40/3	HKU 50/3	HKU 63/3	HKU 80/3	HKU 100/3	HKU 125/3	HKU 160/3	HKU 200/3	HKU 250/3	HKU 320/3	HKU 400/3					
	HKU 40/4	HKU 50/4	HKU 63/4	HKU 80/4	HKU 100/4	HKU 125/4	HKU 160/4	HKU 200/4	HKU 250/4	HKU 320/4	HKU 400/4	HKU 500/4	HKU 630/4	HKU 800/4	HKU 1000/4	
Displacement [cm ³ /rev]	39,6	49,5	65,6	79,2	99,0	123,8	158,4	198	247,5	316,8	396	495	618,7	793	990	
Rated Flow* [l/min]	4	5	6	8	10	13	16	20	25	32	40	50	63	80		
Rated Pressure [bar]	160												140		100	
Max. Cont. Pressure in Line T - P _T [bar]	25															
Max. Torque at Servoamplifying [Nm]	6 (by P _{T,max})															
Max. Torque w/o Servoamplifying [Nm]	120															
Weight, avg. [kg]	5,3	5,4	5,5	5,6	5,7	5,8	6,0	6,3	6,5	7,0	7,4	8,0	8,7	9,6	10,6	
Dimension A [mm]	130,8	132,2	133,9	136,2	138,8	142,2	146,8	152,2	158,8	168,2	178,8	192	209,3	232,2	258,6	

* Rated Flow at 100 RPM.

DIMENSIONS AND MOUNTING DATA

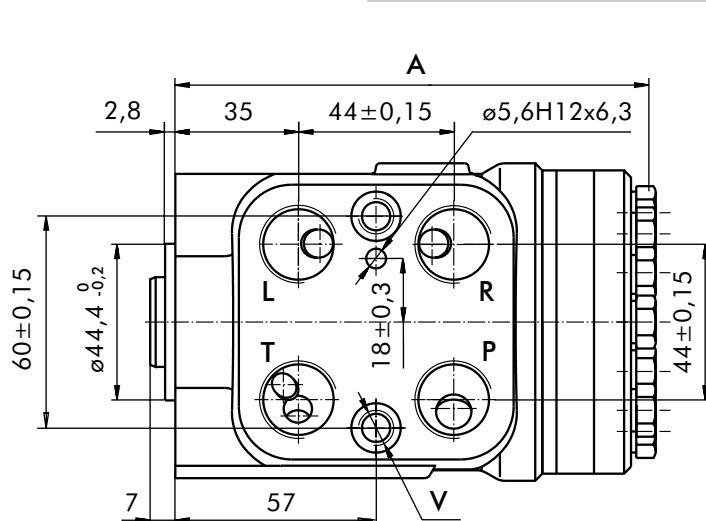

The ports are shown in the Table of page 7.

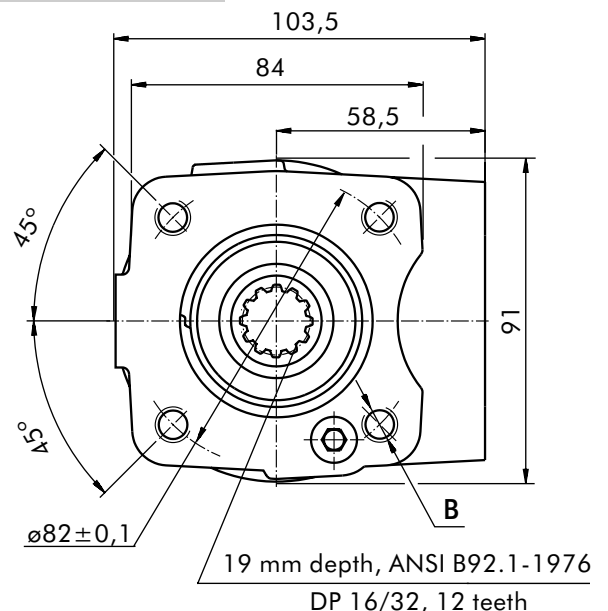

HYDROSTATIC STEERING UNIT TYPE HKU.../7

The HKU.../7 is a "Closed Center - Non Load Reaction" hydrostatic steering unit, designed for integration into systems with built-in hydroaccumulator, achieving minimal energy losses.

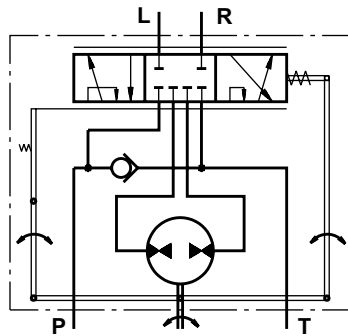

"Closed Center - Non Load Reaction"
Version 7 - HKU.../7

When connecting to a differential cylinder the L and R ports of the steering unit must be connected as follows: L to the greater piston area, and R - to the smaller one.

For the "Closed Center - Non Load Reaction" and "Closed Center - Non Reaction and Load Sensing" steering units it is possible to observe Thermal Shock - condition caused when the hydraulic system has operated for some time without turning the steering wheel, causing the fluid in the reservoir and the system to heat up while the steering unit is relatively cool (i.e. there is more than 50°F [10°C] difference in the temperature). If, under the condition of Thermal Shock, the steering wheel is turned very quickly, it is possible to experience temporary seizure and have the internal parts of the steering unit damaged. The temporary seizure may be followed by a total free wheeling.

SPECIFICATION DATA

Parameters	Type															
	HKU 40/7	HKU 50/7	HKU 63/7	HKU 80/7	HKU 100/7	HKU 125/7	HKU 158/7	HKU 160/7	HKU 198	HKU 200/7	HKU 247,5	HKU 316,8	HKU 396	HKU 495	HKU 618,7	HKU 793
Displacement, [cm ³ /U]	39,6	49,5	65,6	79,2	99,0	123,8	158,4	198	247,5	316,8	396	495	618,7	793		
Rated Flow*, [l/min]	4	5	6	8	10	13	16	20	25	32	40	50	63	80		
Rated Pressure, [bar]	175															
Max. Cont. Pressure in Line T, [bar]	20															
Max. Torque at Servoamplifying, [Nm]	6 (by P _T max)															
Max. Torque w/o Servoamplifying, [Nm]	120															
Weight, [kg]	5,3	5,4	5,5	5,6	5,7	5,8	6,0	6,3	6,5	7,0	7,4	8,0	8,7	9,6		
Dimension A, [mm]	130,8	132,2	133,9	136,2	138,8	142,2	146,8	152,2	158,8	168,2	178,8	192	209,3	232,2		

* Rated Flow at 100 RPM.

DIMENSIONS AND MOUNTING DATA

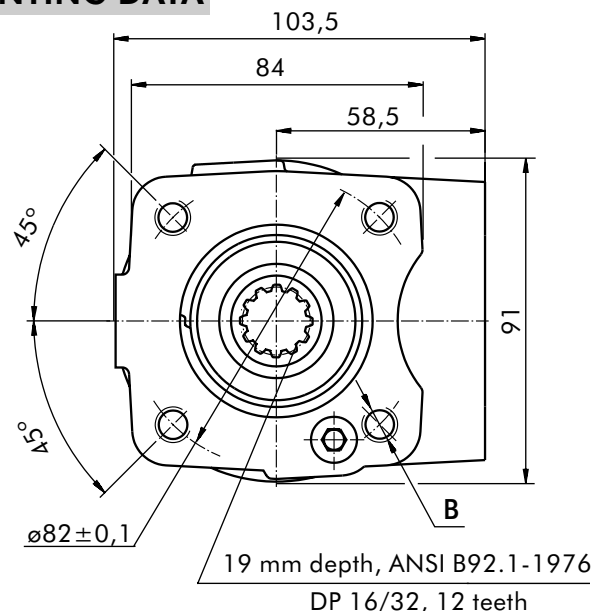
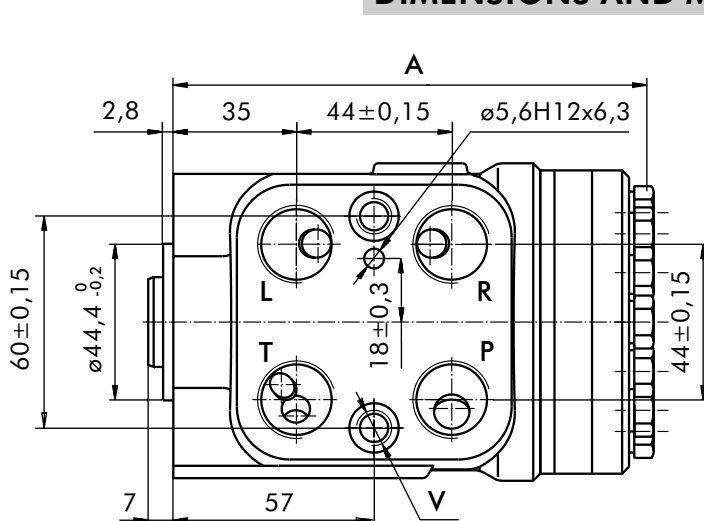

The ports are shown in the Table of page 7.

THREADED PORTS

Code	Ports - P, T, R, L Thread	Column Mounting Thread - B	Valve Mounting Thread - V
-	G1/2 17 mm depth	4 x M10 18 mm depth	2 x M10x1 16 mm depth
A	3/4 - 16 UNF O-ring 17 mm depth	4x 3/8 - 16 UNC 15,7 mm depth	2 x 3/8 - 24 UNF 14,2 mm depth
M	M22x1,5 17 mm depth	4 x M10 18 mm depth	2 x M10x1 16 mm depth

ORDER CODE

	1	2	3	4	5
H K U		/	-		

Pos.1 - Displacement code (see Specification Data)

40	- 39,6 [cm ³ /rev]
50	- 49,5 [cm ³ /rev]
63	- 65,6 [cm ³ /rev]
80	- 79,2 [cm ³ /rev]
100	- 99,0 [cm ³ /rev]
125	- 123,8 [cm ³ /rev]
160	- 158,4 [cm ³ /rev]
200	- 198,0 [cm ³ /rev]
250	- 247,5 [cm ³ /rev]
320	- 316,8 [cm ³ /rev]
400	- 396,0 [cm ³ /rev]
500	- 495,0 [cm ³ /rev]
630	- 618,7 [cm ³ /rev]
800	- 792,0 [cm ³ /rev]
1000	- 990,0 [cm ³ /rev]

Pos.2 - Versions

3	- Version 3 "Open Center - Load Reaction"
4	- Version 4 "Open Center - Non Load Reaction"
7	- Version 7 "Closed Center - Non Load Reaction"

Pos.3 - Ports

omit	- BSPP (ISO 228)
A	- SAE (ANSI B 1.1 - 1982)
M	- Metric (ISO 262)

Pos.4 - Option (Paint)*

omit	- No Paint
P	- Painted
PC	- Corrosion Protected Paint

Pos.5 - Design Series

omit	- Factory specified
------	---------------------

NOTES:

* Colour at customer's request.

The steering units are mangano-phosphatized as standard.

HYDROSTATIC STEERING UNIT TYPE HKU.../4PB



The hydrostatic steering unit is available for steering medium and large sized transport vehicles as building and agricultural machines.

HKU.../4PB works as standard steering unit with auxiliary port destined for flow providing additional vehicles functions. When the steering wheel is not turned, the flow will be delivered to port PB. After steering wheel has been turned a part of flow will be deviated to the steering unit and the flow through port PB will be inconstant.

It is not recommended to use this unit in systems with auxiliary functions during the vehicle steering.

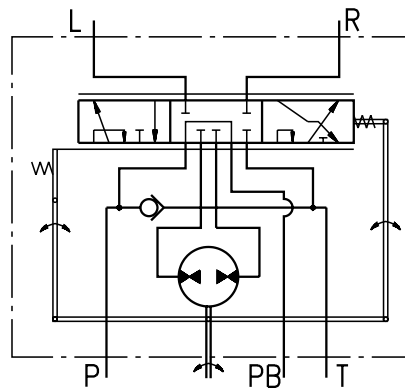

"Open Center - Non Load Reaction"
HKU.../4PB - Power Beyond

SPECIFICATION DATA

Parameters	Type					
	HKU 40/4PB	HKU 50/4PB	HKU 63/4PB	HKU 80/4PB	HKU 100/4PB	HKU 125/4PB
Displacement, [cm ³ /rev]	39,6	49,5	65,6	79,2	99,0	123,8
Rated Flow -5 Port (Power Beyond) [l/min]	15					
Rated Pressure, [bar]	125					
Max. Pressure in Line PB, [bar]	125					
Max. Cont. Pressure in Line T - P _T , [bar]	10					
Max. Torque at Servoamplifying, [Nm]	2,8 (by P _{T,max})					
Max. Torque w/o Servoamplifying, [Nm]	135					
Weight, [kg]	5,3	5,4	5,5	5,6	5,7	5,8
Dimension A, [mm]	130,8	132,2	133,9	136,2	138,8	142,2

DIMENSIONS AND MOUNTING DATA

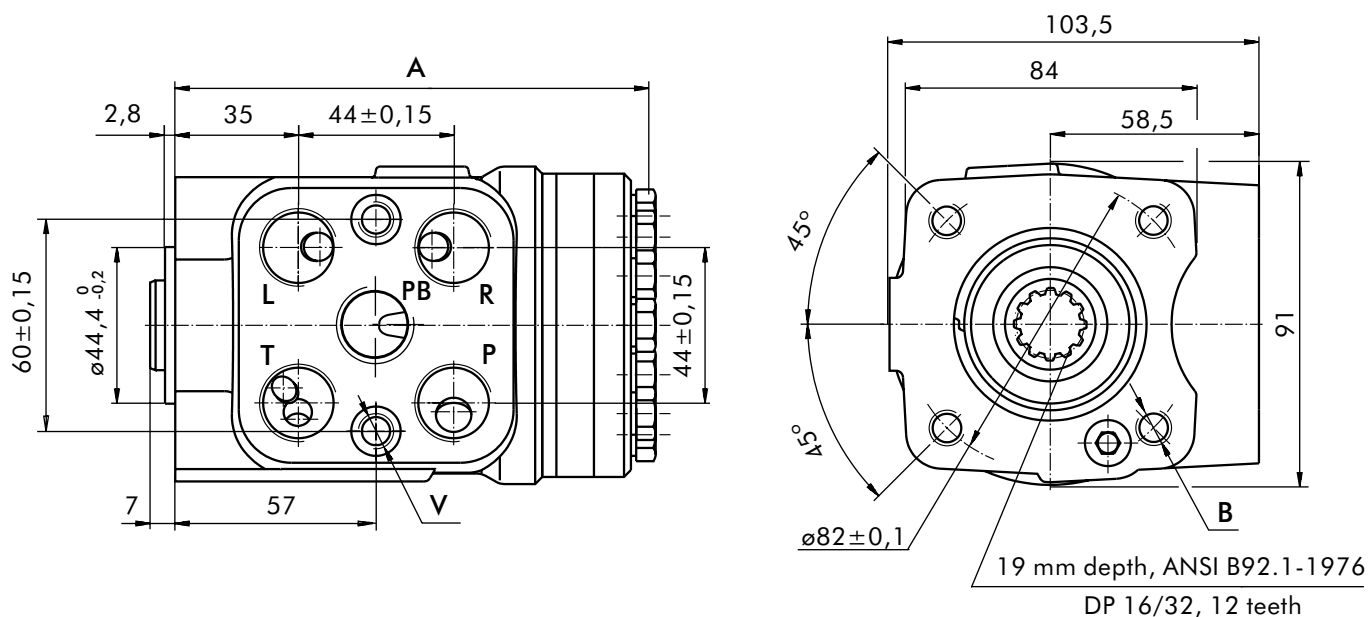

THREADED PORTS for HKU.../4PB

code	Ports - P, T, R, L, PB Thread	Column Mounting Thread - B	Valve Mounting Thread - V
-	G3/8 17 mm depth	4 x M10 18 mm depth	2 x M10x1 16 mm depth
A	9/16 - 18 UNF O-ring 17 mm depth	4x 3/8 - 16 UNC 15,7 mm depth	2 x 3/8 - 24 UNF 14,2 mm depth

ORDER CODE for HKU.../4PB

	1	2	3	4	5
HKU		/ 4PB	-		

Pos.1 - **Displacement code** (see Specification Data)

40	- 39,6 [cm ³ /rev]
50	- 49,5 [cm ³ /rev]
63	- 65,6 [cm ³ /rev]
80	- 79,2 [cm ³ /rev]
100	- 99,0 [cm ³ /rev]
125	- 123,8 [cm ³ /rev]

Pos.2 - **Versions**

4PB - Version 4 "Open Center - Non Load Reaction" with 5 ports(Power Beyond)

Pos.3 - **Ports**

- omit - BSPP (ISO 228)
- A** - SAE (ANSI B 1.1 - 1982)

Pos.4 - **Option (Paint)***

- omit - No Paint
- P** - Painted
- PC** - Corrosion Protected Paint

Pos.5 - **Design Series**

- omit - Factory specified

NOTES:

* Colour at customer's request.

The steering units are mangano-phosphatized as standard.

HYDROSTATIC STEERING UNIT TYPE HKUQ.../4



HKUQ.../4 is a new series of hydrostatic steering units with an additionally increased flow. The hydrostatic steering unit type HKUQ.../4 is available for steering medium and large sized vehicles, allowing easy control either in servo-amplified mode or in emergency operation.

HKUQ.../4 is an "Open Center-Non Load Reaction" hydrostatic steering in which restrictor for amplifying factor from 1,3 to 2,5 is built-in.

In accordance with the size of the gear wheel set and amplifying factor, HKUQ...4 has the following working volume:

- from 80 cm³ to 200 cm³ for emergency operation mode (manual steering without servo-amplifying);

- from 100 cm³ to 500 cm³ for normal operation mode (with total flow amplifying).

There is no servo-amplifying of flow if low steering speed till 10 min⁻¹ is applied. In steering speed increase over 20 min⁻¹ there is total servo-amplifying of flow. In this mode gear wheel set flow and restrictor flow are added.

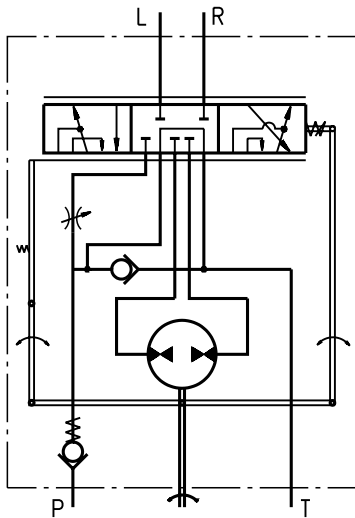

"Open Center - Non Load Reaction"
HKUQ.../4

VARIABLE AMPLIFYING FACTOR

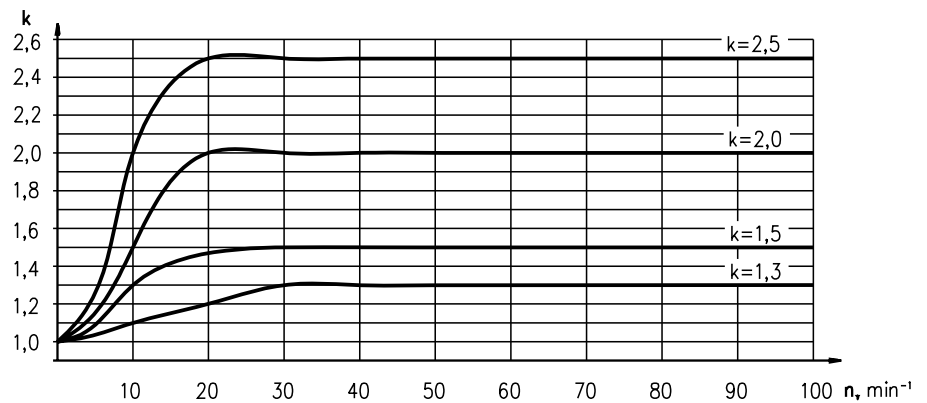

SPECIFICATION DATA

Parameters	Type																			
	HKUQ 80/.../4				HKUQ 100/.../4				HKUQ 125/.../4				HKUQ 160/.../4				HKUQ 200/.../4			
Displacement - without servo-amplifying (in emergency mode) - with servo-amplifying [cm ³ /rev]	79,2				99,0				123,8				158,4				198			
Rated Flow* [l/min]	10	12,5	16	20	12,5	16	20	25	16	20	25	32	20	25	32	40	25	32	40	50
Amplifying Factor (at shaft revolution over 20 min ⁻¹)	1,3	1,5	2,0	2,5	1,3	1,5	2,0	2,5	1,3	1,5	2,0	2,5	1,3	1,5	2,0	2,5	1,3	1,5	2,0	2,5
Rated Pressure [bar]	160																			
Max. Cont. Pressure in Line T - P _T [bar]	25																			
Max. Torque at Servoamplifying [Nm]	6 (by P _{T,max})																			
Max. Torque w/o Servoamplifying [Nm]	120																			
Weight, avg. [kg]	5,6				5,7				5,8				6,0				6,3			
Dimension A [mm]	136,2				138,8				142,2				146,8				152,2			

* Rated Flow at 100 RPM.

DIMENSIONS AND MOUNTING DATA

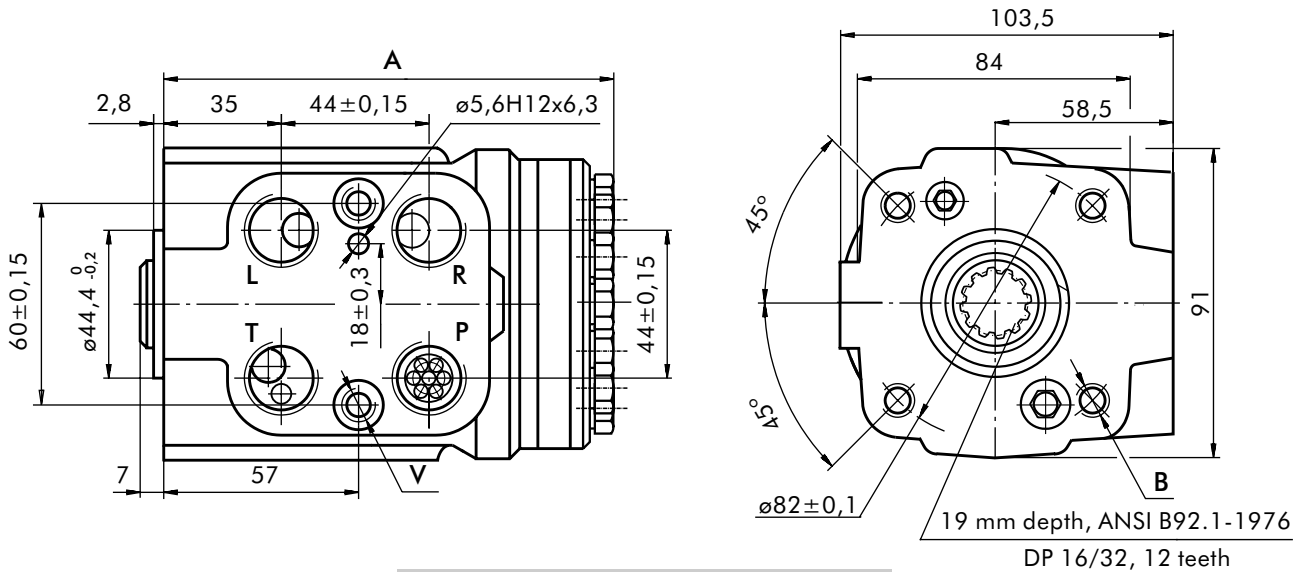

THREADED PORTS for HKUQ...

code	Ports - P*, T, R, L Thread	Column Mounting Thread - B	Valve Mounting Thread - V
-	G1/2 17 mm depth	4 x M10 18 mm depth	2 x M10x1 16 mm depth
A	3/4 - 16 UNF O-ring 17 mm depth	4x 3/8 - 16 UNC 15,7 mm depth	2 x 3/8 - 24 UNF 14,2 mm depth
M	M22x1,5 17 mm depth	4 x M10 18 mm depth	2 x M10x1 16 mm depth
MX	M20x1,5 17 mm depth	4 x M10 18 mm depth	2 x M10x1 16 mm depth

*Threaded Port **P** min 16 mm depth.

ORDER CODE for HKUQ...

1	2	3	4	5	6
HKUQ	/	/	4	-	

Pos.1 - **Displacement code** (see Specification Data page 10)

- 80** - 79,2 [cm³/rev]
- 100** - 99,0 [cm³/rev]
- 125** - 123,8 [cm³/rev]
- 160** - 158,4 [cm³/rev]
- 200** - 198,0 [cm³/rev]

Pos.2 - **Displacement with amplifying factor 1,3; 1,5; 2,0 or 2,5**

80	100	125	160	200
----	-----	-----	-----	-----

100	•							
125	•	•						
160	•	•	•					
200	•	•	•	•				
250	•	•	•	•	•			• k=1,3
320	•	•	•	•	•	•		• k=1,5
400	•	•	•	•	•	•	•	• k=2,0
500	•	•	•	•	•	•	•	• k=2,5

Pos.3 - **Versions**

- 4** - Version 4 "Open Center - Non Load Reaction"

Pos.4 - **Ports**

- omit - BSPP (ISO 228)
- A** - SAE (ANSI B 1.1 - 1982)
- M** - Metric (ISO 262)
- MX** - Metric (ISO 262)

Pos.5 - **Option (Paint)****

- omit - No Paint
- P** - Painted
- PC** - Corrosion Protected Paint

Pos.6 - **Design Series**

- omit - Factory specified

NOTES:

- * Exemplary designation of steering unit with displacement 200 cm³ and amplifying factor 2,5 HKUQ 200/500/4
- ** Colour at customer's request.

The steering units are mangano-phosphatized as standard.

HYDROSTATIC STEERING UNITS TYPE HKUS.../3, 4, 8



The HKUS Hydrostatic Steering unit is based on the HKU unit but has built-in relief and check valves. Thus M+S Hydraulic achieves one very compact steering unit which reduces the need for additional hydraulic components in the system.

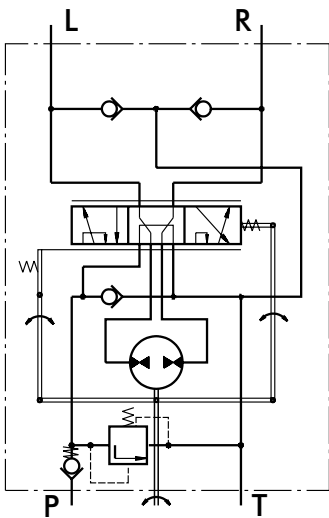

"Open Center - Load Reaction"
With Built-in Valves
Version 3 - HKUS.../3

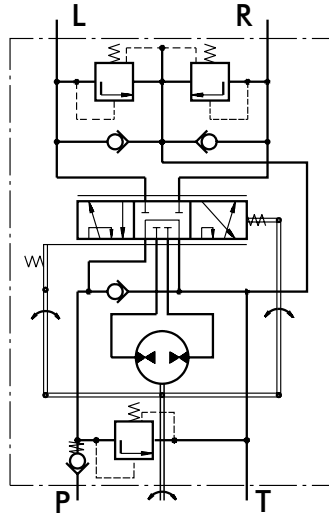

"Open Center - Non Load Reaction"
With Built-in Valves
Version 4 - HKUS.../4

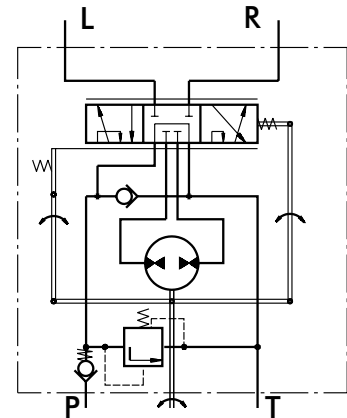

"Open Center - Non Load Reaction"
With Built-in Valve
Version 8 - HKUS.../8

SPECIFICATION DATA

Parameters	Type											
	HKUS 40/3,4,8	HKUS 50/3,4,8	HKUS 63/3,4,8	HKUS 80/3,4,8	HKUS 100/3,4,8	HKUS 125/3,4,8	HKUS 160/3,4,8	HKUS 200/3,4,8	HKUS 250/3,4,8	HKUS 320/3,4,8	HKUS 400/3,4,8	
Displacement [cm ³ /rev]	39,6	49,5	65,6	79,2	99,0	123,8	158,4	198	247,5	316,8	396	
Rated Flow* [l/min]	4	5	6	8	10	13	16	20	25	32	40	
Rated Pressure [bar]	160											
Relief Valve Pressure Settings** [bar]				80	100	125	150					
Shock Valves Pressure Settings*** [bar]				140	160	180	200					
Max.Cont. Pressure in Line T - P _T [bar]	25 (50 - for HKUS.../8)											
Max.Torque at Servoamplifying [Nm]	6 (by P _{T,max})											
Max.Torque w/o Servoamplifying [Nm]	120											
Weight, avg. [kg]	5,3	5,5	5,6	5,7	5,8	5,9	6,2	6,5	6,6	7,2	7,8	
Dimension A [mm]	130,8	132,2	133,9	136,2	138,8	142,2	146,8	152,2	158,8	168,2	178,8	

* Rated Flow at 100 RPM.

** Pressure Settings are at Rated Flow (as in the table) and viscosity 21 mm²/s (50° C).

***Pressure Settings are at flow rate of 2 l/min and viscosity 21 mm²/s (50° C).

DIMENSIONS AND MOUNTING DATA

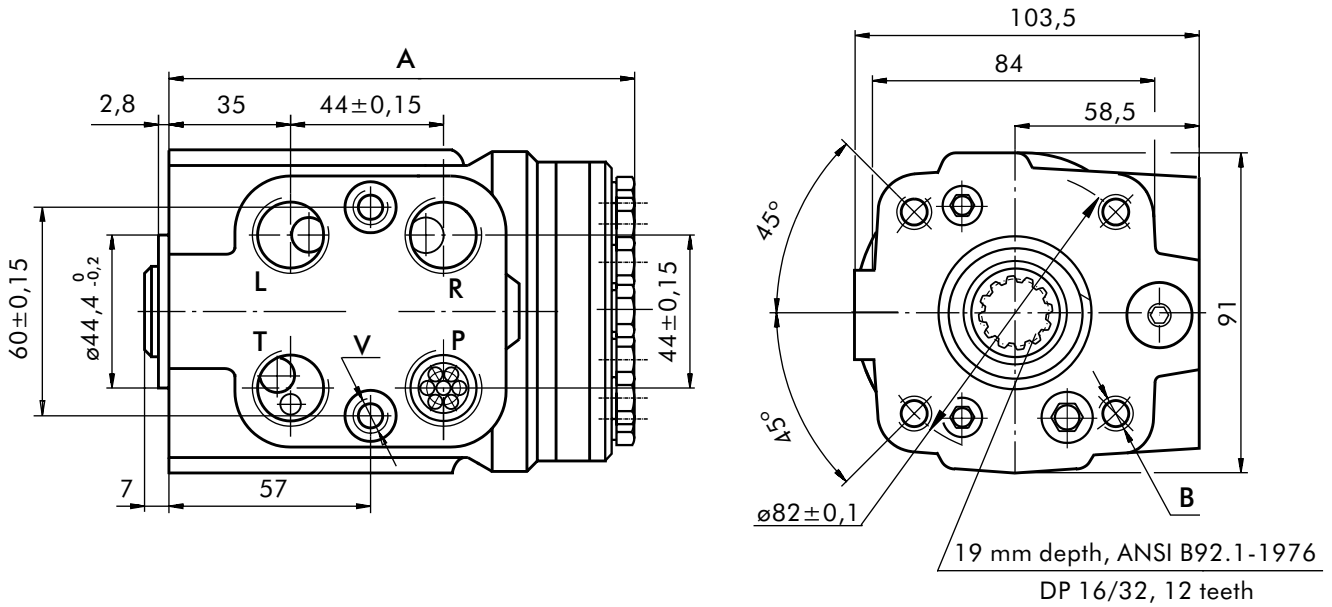

THREADED PORTS

code	Ports - P, T, R, L Thread	Column Mounting Thread - B	Valve Mounting Thread - V
-	G1/2 17 mm depth	4 x M10 18 mm depth	2 x M10x1 16 mm depth
A	3/4 - 16 UNF O-ring 17 mm depth	4x 3/8 - 16 UNC 15,7 mm depth	2 x 3/8 - 24 UNF 14,2 mm depth
M	M22x1,5 17 mm depth	4 x M10 18 mm depth	2 x M10x1 16 mm depth

*Threaded Port **P** min 16 mm depth.

ORDER CODE

	1	2	3	4	5	6
H K U S		/	-			

Pos.1 - Displacement code (see Specification Data)

40	- 39,6 [cm ³ /rev]
50	- 49,5 [cm ³ /rev]
63	- 65,6 [cm ³ /rev]
80	- 79,2 [cm ³ /rev]
100	- 99,0 [cm ³ /rev]
125	- 123,8 [cm ³ /rev]
160	- 158,4 [cm ³ /rev]
200	- 198,0 [cm ³ /rev]
250	- 247,5 [cm ³ /rev]
320	- 316,8 [cm ³ /rev]
400	- 396,0 [cm ³ /rev]

Pos.2 - Versions

3	- Version 3 "Open Center - Load Reaction"
4	- Version 4 "Open Center - Non Load Reaction"
8	- Version 8 "Open Center - Non Load Reaction"

Pos.3 - Relief Valve Pressure Settings, bar

80
100
125
150

Pos.4 - Ports

omit	- BSPP (ISO 228)
A	- SAE (ANSI B 1.1 - 1982)
M	- Metric (ISO 262)

Pos.5 - Option (Paint)*

omit	- No Paint
P	- Painted
PC	- Corrosion Protected Paint

Pos.6 - Design Series

omit	- Factory specified
------	---------------------

Version	Manual Steering Check Valve	Relief Valve	Inlet Check Valve	Cylinder Relief Valve	Anti-Cavitation Valve
3	•	•	•		•
4	•	•	•	•	•
8	•	•	•		

NOTES:

* Colour at customer's request.

The steering units are mangano-phosphatized as standard.

HYDROSTATIC STEERING UNITS TYPE HKU(S).../5(T)(E)(TE)



The HKU(S).../5(T)(E)(TE) range expands the steering units family of M+S Hydraulic with the "Closed Center - Non Reaction and Load Sensing Outlet" version (static hydraulic connection to the priority valve).

This range is manufactured in two versions; for modularly and pipe mounting and therefore were developed the two versions of priority (tracing) valves: PRD... and PRT...

HKU.../5 is designed to be connected with priority valves with built-in relief valves for rated flow up to 160 l/min.

The control hydraulic circuits of the HKU(S).../5(T)(E)(TE) steering units were designed to ensure minimal energy consumption (energy losses) in various hydraulic systems such as those of: fork-lift trucks, agricultural and construction machines and others.

The HKUS.../5E and HKUS.../5TE are equipped with an electrohydraulic relay, mounted in the EL port, which supplies signal to the electric - control system. The relay can be pre-set to normally - open (N.O) or normally - closed (N.C) contacts, with control range from 0,1 to 50 bars. Upon customer's request the relay could be supplied with another type of fixing thread.

*For operation in condition of Thermal Shock see the notes on page 6.

Modularly Mounting

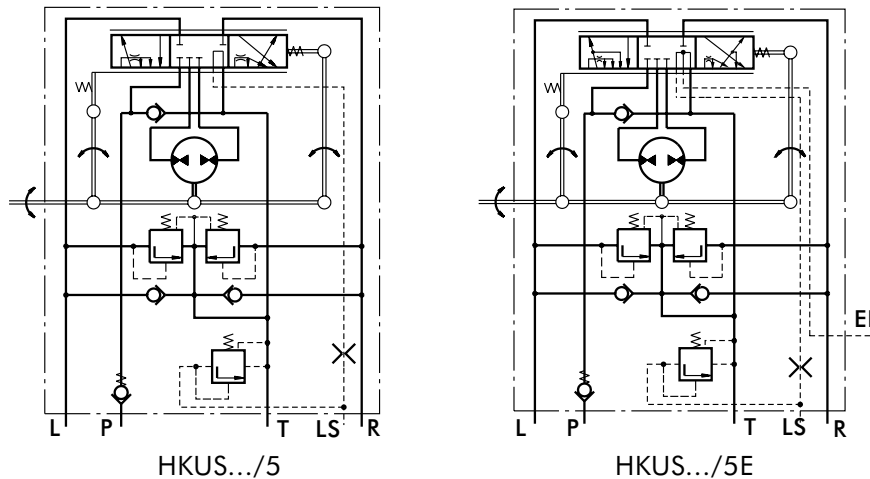

Pipe Mounting

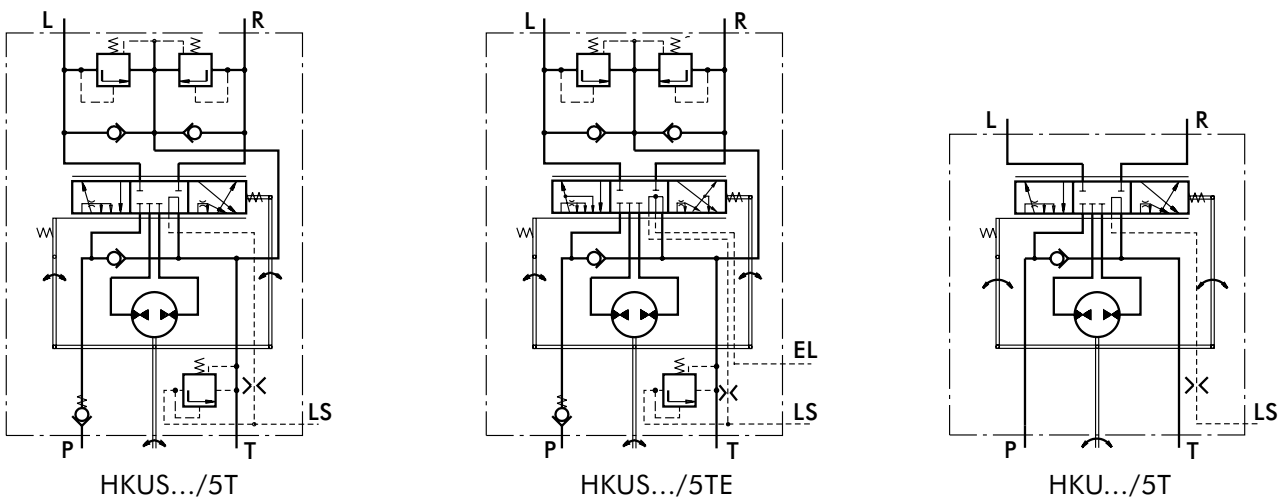

SPECIFICATION DATA

Parameters	Type													
	HKU 40/5T	HKU 50/5T	HKU 63/5T	HKU 80/5T	HKU 100/5T	HKU 125/5T	HKU 160/5T	HKU 200/5T	HKU 250/5T	HKU 320/5T	HKU 400/5T	HKU 500/5T	HKU 630/5T	
	HKUS 40/5...	HKUS 50/5...	HKUS 63/5...	HKUS 80/5...	HKUS 100/5...	HKUS 125/5...	HKUS 160/5...	HKUS 200/5...	HKUS 250/5...	HKUS 320/5...	HKUS 400/5...			
Displacement [cm ³ /rev]	39,6	49,5	65,6	79,2	99,0	123,8	158,4	198	247,5	316,8	396	495	618,7	
Rated Flow* [l/min]	4	5	6	8	10	13	16	20	25	32	40	50	63	
Rated Pressure [bar]	125	150	175											
LS - Valve Pressure Settings** [bar]					80	100	125	150	175					
Shock Valves Pressure Settings*** [bar]					140	160	180	200	240					
Max.Cont. Pressure in Line T - P _T [bar]														20
Max.Torque at Servoamplifying [Nm]														6 (by P _{T max})
Max.Torque w/o Servoamplifying [Nm]														120
Weight, avg. [kg]	5,4	5,5	5,6	5,7	5,8	5,9	6,2	6,5	6,6	7,2	7,8	8	8,7	
Dimension A [mm]	130,8	132,2	133,9	136,2	138,8	142,2	146,8	152,2	158,8	168,2	178,8	192	209,3	

* Rated Flow at 100 RPM.

** Pressure Settings are at flow rate of 6 l/min and viscosity 21 mm²/s (50° C).

***Pressure Settings are at flow rate of 2 l/min and viscosity 21 mm²/s (50° C).

DIMENSIONS AND MOUNTING DATA - HKUS.../5

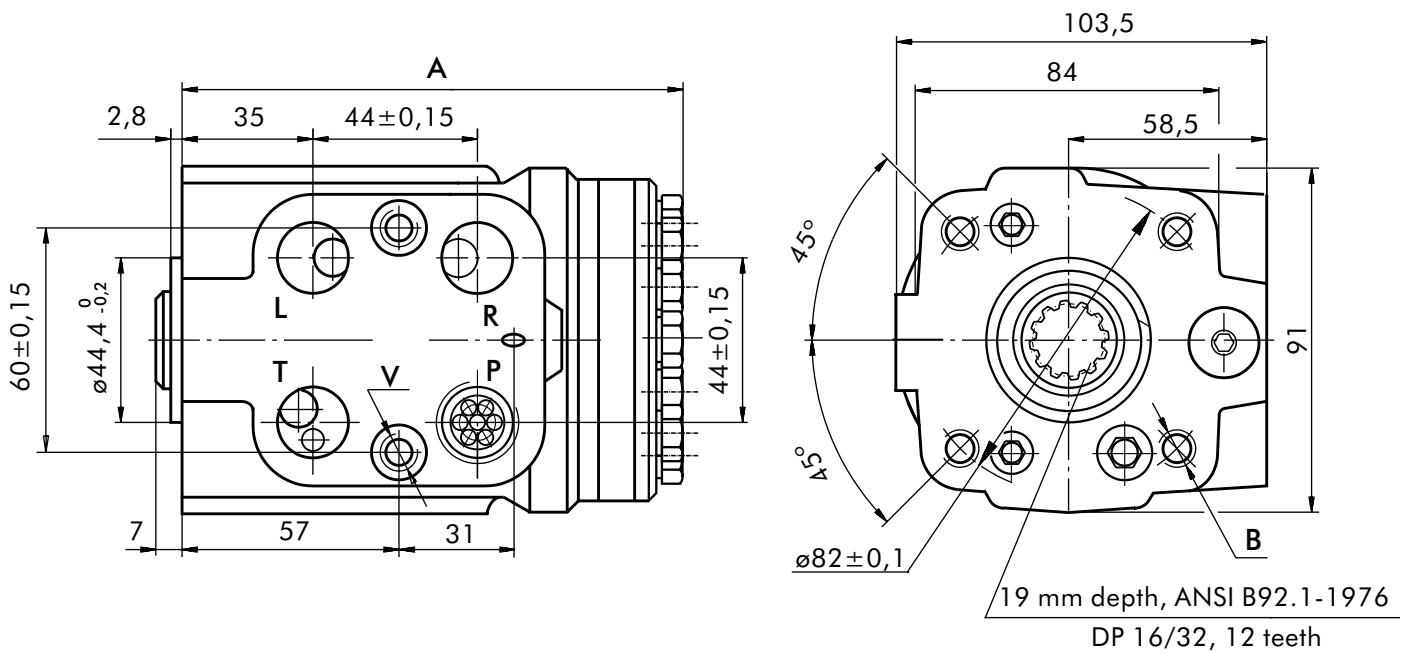

DIMENSIONS AND MOUNTING DATA - HKUS.../5E

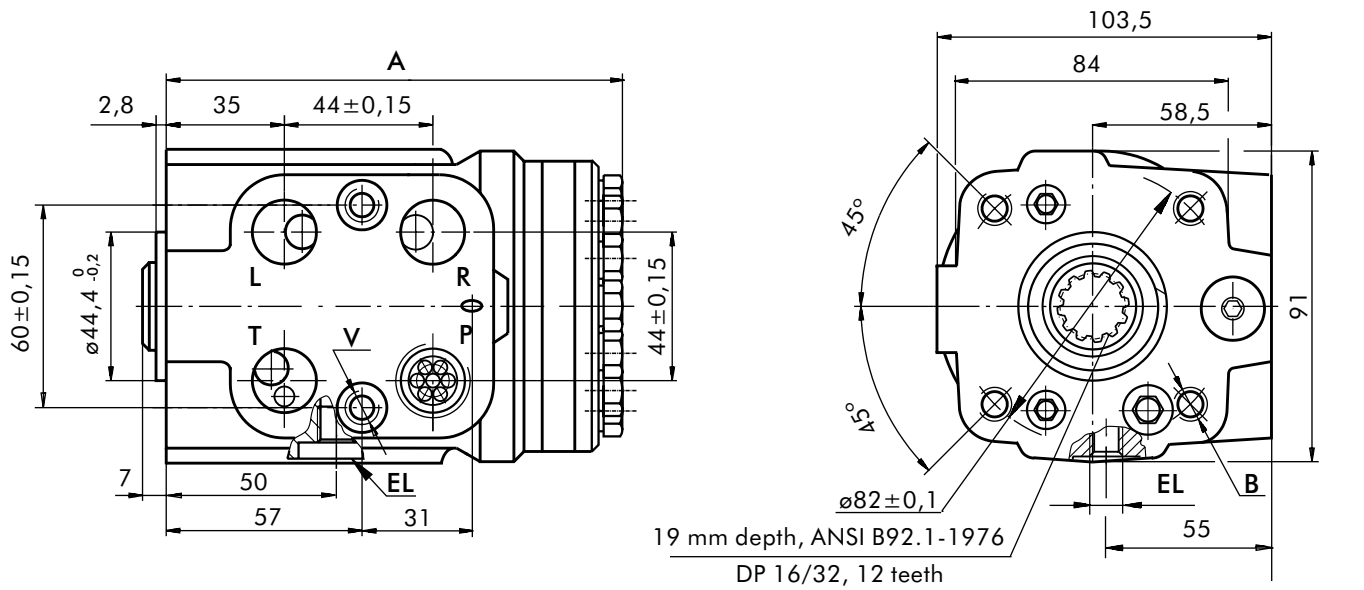

DIMENSIONS AND MOUNTING DATA - HKUS.../5T

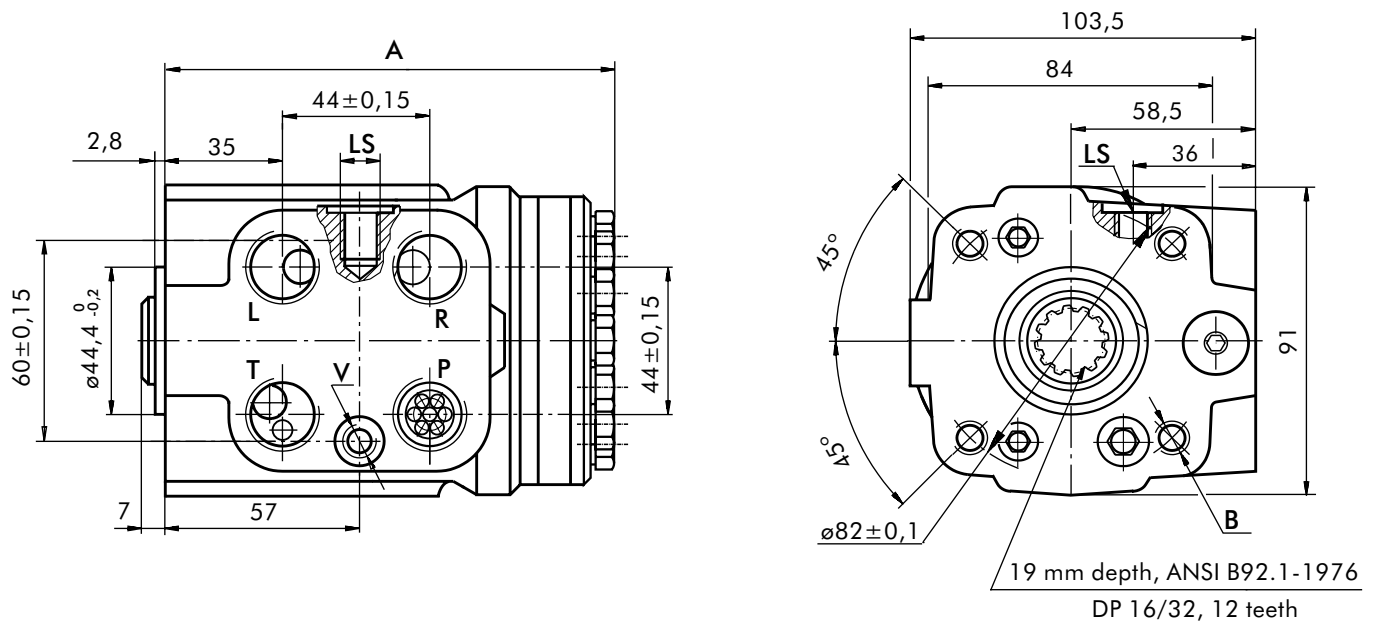

* The ports are shown in the Table of page 18.

DIMENSIONS AND MOUNTING DATA - HKUS.../5TE

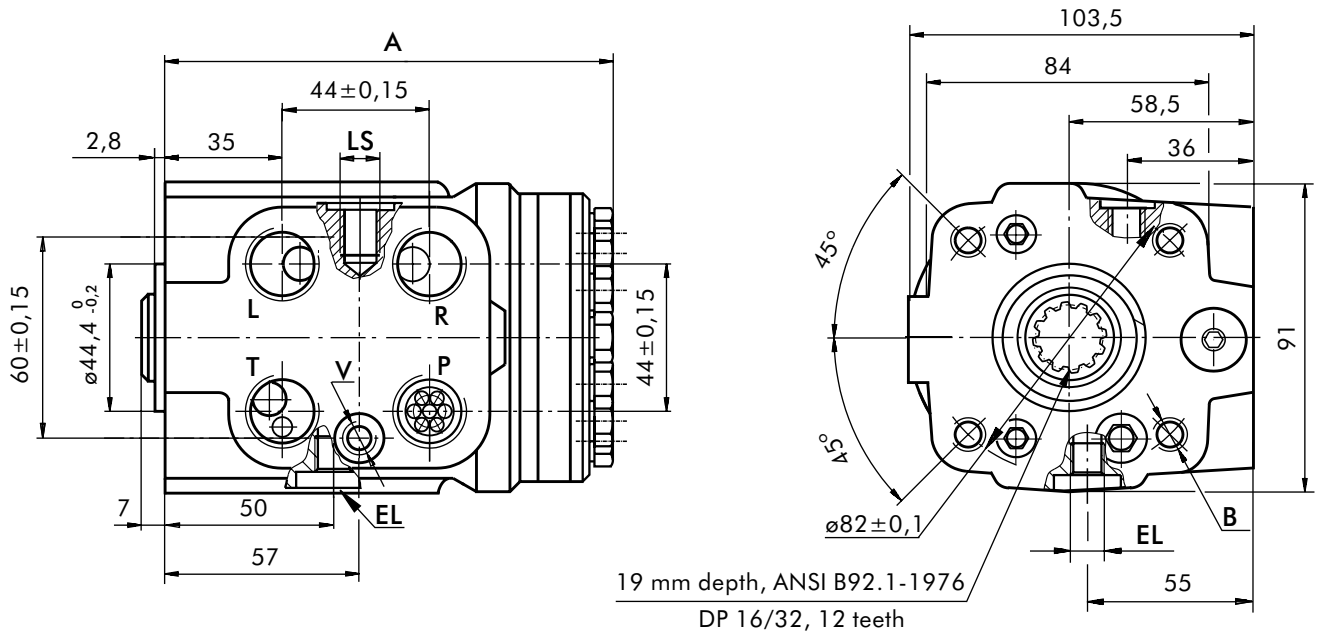

DIMENSIONS AND MOUNTING DATA - HKU.../5T

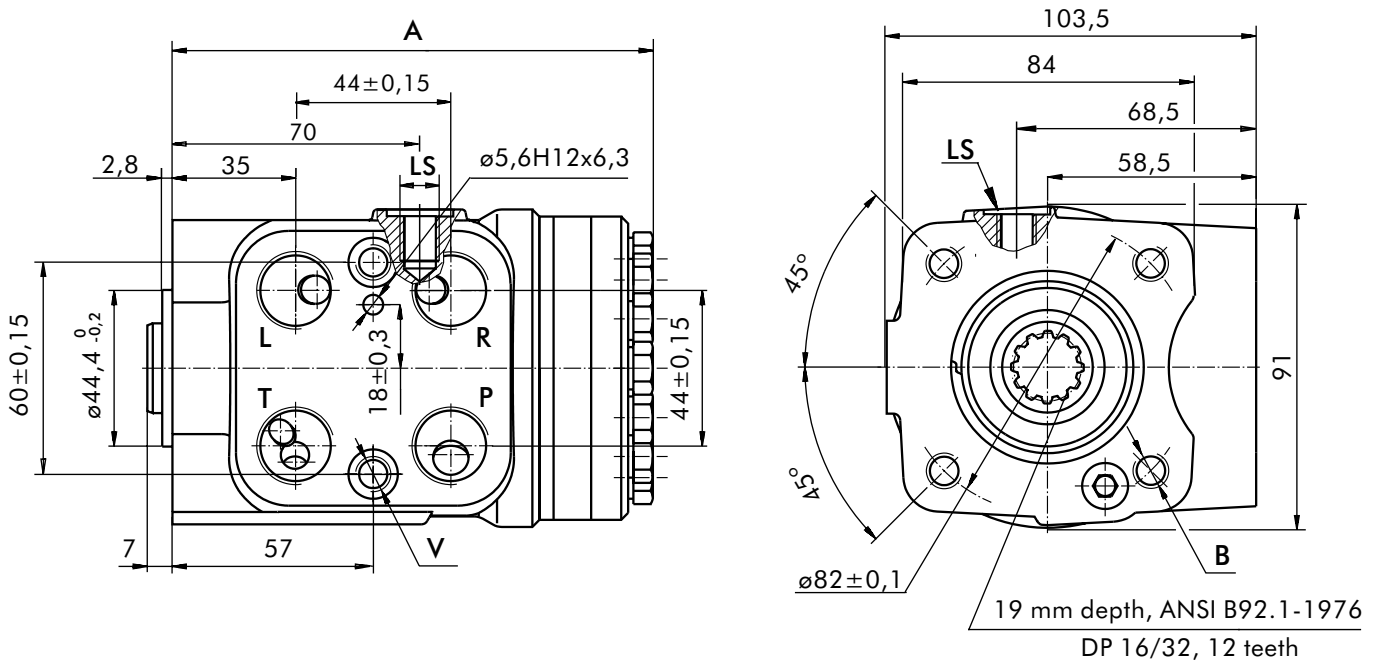

THREADED PORTS

code	Ports - *P, T, R, L Thread	Column Mounting Thread - B	Valve Mounting Thread- V	LS - Port	EL - Port
-	G1/2 17 mm depth	4 x M10 18 mm depth	2 x M10x1 16 mm depth	G1/4 14 mm depth	M10x1 10 mm depth
A	3/4 - 16 UNF O-ring 17 mm depth	4 x 3/8 - 16 UNC 15,7 mm depth	2 x 3/8 - 24 UNF 14,2 mm depth	7/16 - 20 UNF O-ring 12,7 mm depth	7/16 - 20 UNF O-ring 12,7 mm depth
M	M22x1,5 17 mm depth	4 x M10 18 mm depth	2 x M10x1 16 mm depth	G1/4 14 mm depth	M10x1 10 mm depth

*Threaded Port P min 16 mm.

ORDER CODE for HKUS.../5...

	1		2	3	4	5		6		7	8
HKUS		/	5			-		-			

Pos.1 - Displacement code (see Specification Data)

40	- 39,6 [cm ³ /rev]
50	- 49,5 [cm ³ /rev]
63	- 65,6 [cm ³ /rev]
80	- 79,2 [cm ³ /rev]
100	- 99,0 [cm ³ /rev]
125	- 123,8 [cm ³ /rev]
160	- 158,4 [cm ³ /rev]
200	- 198,0 [cm ³ /rev]
250	- 247,5 [cm ³ /rev]
320	- 316,8 [cm ³ /rev]
400	- 396,0 [cm ³ /rev]

Pos.2 - Versions

5	- Version 5 "Closed Center - Non Reaction and Load Sensing Outlet"
----------	--

Pos.3 - Priority Valve Connection

omit	- Modularly Mounting
T	- Pipe Mounting

Pos.4 - Electric Signal Connection

omit	- without electric signal connection
E	- with electric signal connection

Pos.5 - LS - Valve Pressure Settings, bar

80	100	125	150	175
-----------	------------	------------	------------	------------

Pos.6 - Ports

omit	- BSPP (ISO 228)
A	- SAE (ANSI B 1.1 - 1982)
M	- Metric (ISO 262)

Pos.7 - Option (Paint)*

omit	- No Paint
P	- Painted
PC	- Corrosion Protected Paint

Pos.8 - Design Series

omit	- Factory specified
------	---------------------

NOTES:

* Colour at customer's request.
The steering units are mangano-phosphatized as standard.

ORDER CODE for HKU.../5T...

	1		2	3	4	5	6
HKU		/	5	T	-		

Pos.1 - Displacement code (see Specification Data)

40	- 39,6 [cm ³ /rev]
50	- 49,5 [cm ³ /rev]
63	- 65,6 [cm ³ /rev]
80	- 79,2 [cm ³ /rev]
100	- 99,0 [cm ³ /rev]
125	- 123,8 [cm ³ /rev]
160	- 158,4 [cm ³ /rev]
200	- 198,0 [cm ³ /rev]
250	- 247,5 [cm ³ /rev]
320	- 316,8 [cm ³ /rev]
400	- 396,0 [cm ³ /rev]
500	- 495,0 [cm ³ /rev]
630	- 618,7 [cm ³ /rev]

Pos.2 - Versions

5	- Version 5 "Closed Center - Non Reaction and Load Sensing Outlet"
----------	--

Pos.3 - Priority Valve Connection

T	- Pipe Mounting
----------	-----------------

Pos.4 - Ports

omit	- BSPP (ISO 228)
A	- SAE (ANSI B 1.1 - 1982)
M	- Metric (ISO 262)

Pos.5 - Option (Paint)*

omit	- No Paint
P	- Painted
PC	- Corrosion Protected Paint

Pos.6 - Design Series

omit	- Factory specified
------	---------------------

NOTES:

* Colour at customer's request.
The steering units are mangano-phosphatized as standard.

VALVE BLOCKS FOR HKU AND XY TYPE BKH...



The M+S Hydraulic BKH valves are developed to protect the components of the hydraulic circuit: pumps, steering units and cylinders - from overloads, impacts and cavitation. Some of their advantages are: easy integration into any hydraulic circuit, easy mounting to the steering unit, and quick and easy hose connections. Depending on the design and the built in valves the BKH valves can be divided into 6 types: BKH1 ... BKH5 and BKHR, with BKH5 designed for XY steering units only. The maximum flow rate is in compliance with the whole range of HKU and XY steering units but no more than 80 l/min. The pressure settings for the entry relief valves and the shock valves are given in the table.

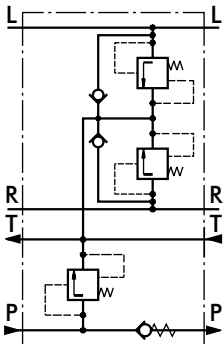

BKH1, BKHR

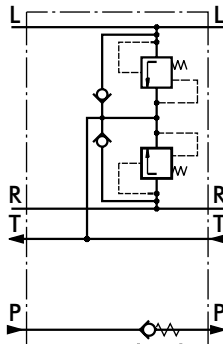

BKH2

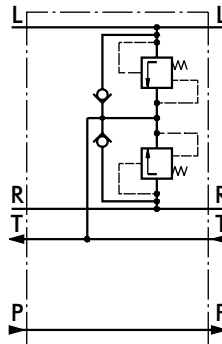

BKH3

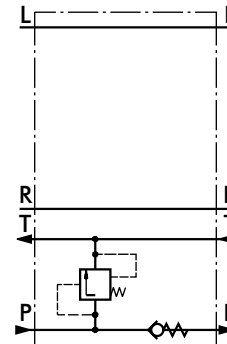

BKH4

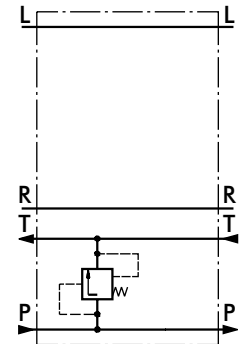

BKH5

SPECIFICATION DATA

Parameters	Type									
	BKH1, BKHR				BKH2	BKH3	BKH4, BKH5			
Rated Flow [l/min]	80									
Rated Pressure [bar]	160									
Relief Valve Pressure Settings* [bar]	80	100	125	150	-	-	80	100	125	150
Shock Valves Pressure Settings** [bar]	140	160	180	200	200	240				
Weight, avg. [kg]	1,8 ; 2,3				1,8		1,8			

* Pressure Settings are at flow rate of 30 l/min and viscosity 21 mm²/s (50° C).

**Pressure Settings are at flow rate of 2 l/min and viscosity 21 mm²/s (50° C).

DIMENSIONS AND MOUNTING DATA - BKH1, 2, 3, 4

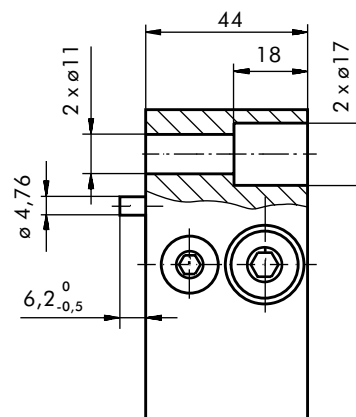
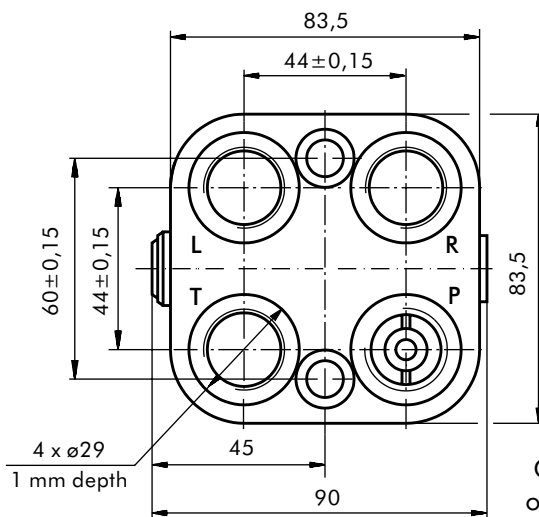

Code	Ports - P, T, R, L Thread
-	G1/2 20 mm depth
A	3/4 - 16 UNF O-ring 20 mm depth
M	M22x1,5 20 mm depth

Connection to the HKU is done with 2 screws M10x1x40-8.8 DIN 912 or with 2 screws 3/8-24 UNF ANSI B18.3-76; 37,5 mm long. Tightening torque: 2,5±0,5 daNm

DIMENSIONS AND MOUNTING DATA - BKHR

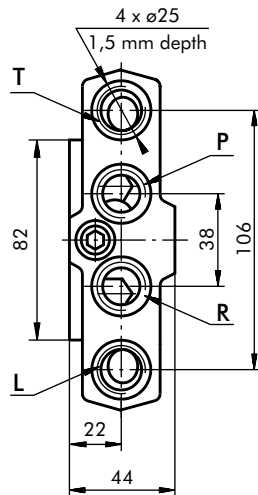
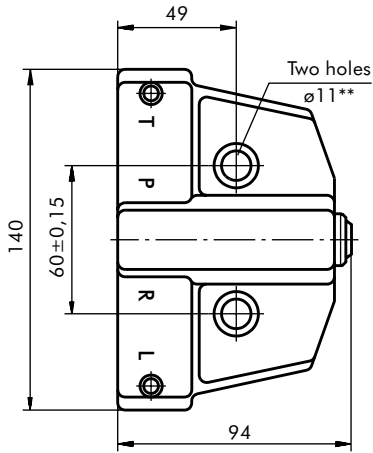

code	Ports - P, T, R, L Thread
A	3/4 - 16 UNF O-ring 22 mm depth
M	M18x1,5 22 mm depth

**Connection to the HKU is done with 2 screws M10x1x40-8.8 DIN 912 or with 2 screws 3/8-24 UNF ANSI B18.3-76; 37,5 mm long. Tightening torque: 2,5±0,5 daNm

DIMENSIONS AND MOUNTING DATA - BKH5

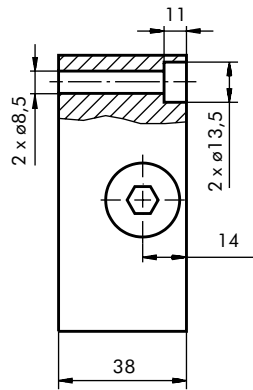
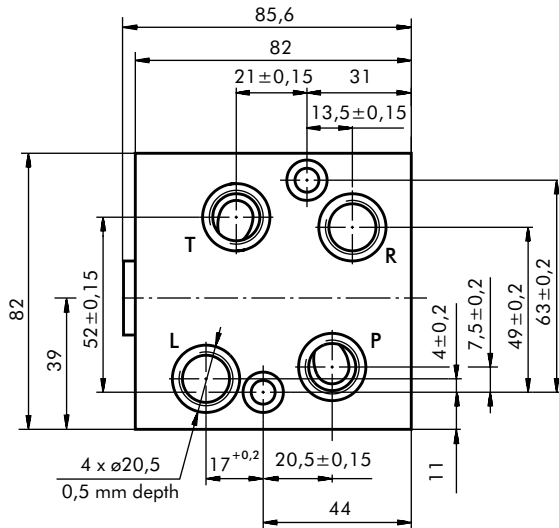

code	Ports - P, T, R, L Thread
M	M16x1,5 14 mm depth

Connection to the XY is done with 2 screws M8x40-8.8 DIN 912
Tightening torque: 2,5±0,5 daNm

ORDER CODE

	1	2	3	4	5
B K H	-	-			

Pos.1 - Versions*

R	1	2	3	4	5	
•	•			•	•	-Input relief valve on line "P".
•	•	•		•		-Input check (non-return) valve on line "P".
•	•	•	•			-Shock valves on lines "R" and "L".
•	•	•	•			-Anti-cavitation valves on lines "R" and "L".

Pos.2 - Relief Valve Pressure Settings, bar**

80	100	125	150
-----------	------------	------------	------------

Pos.3 - Ports

- omit - BSPP (ISO 228)
- A** - SAE (ANSI B 1.1 - 1982)
- M** - Metric (ISO 262)

Pos.4 - Option (Paint)***

- omit - No Paint
- P** - Painted
- PC** - Corrosion Protected Paint

Pos.5 - Design Series

- omit - Factory specified

NOTES: * Versions **R, 1, 2, 3, 4**-for HKU; **5** - for XY
** That does not concern version **2** and **3**.
*** The colour is by customer's request.

The valve blocks are mangano-phosphatized as standard.

PRIORITY VALVES FOR HKUS.../5... TYPE PR...

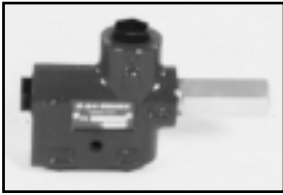
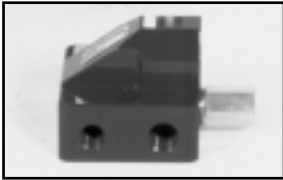

The Priority Valves distribute and trace the hydraulic flow from the supply pump of the hydraulic system to the hydraulic components which control and run the vehicle.

The Priority Valves are used only with the HKUS.../5(E)(T)(TE) hydrostatic steering units. When connected, the steering unit and the priority valve represent sophisticated hydraulic tracing system that controls the flow in both main pipelines of the hydraulic system (the working and control one) at any time of its operation.

As a static signal, the "LS" signal must be used in systems with circuit stability. The connection between the PRT, PRTA priority valves and the HKUS.../5T(TE) steering units has to be as short as possible, but should not exceed 1,5m (for iron pipe with $\varnothing 4$

Modulary Mounting

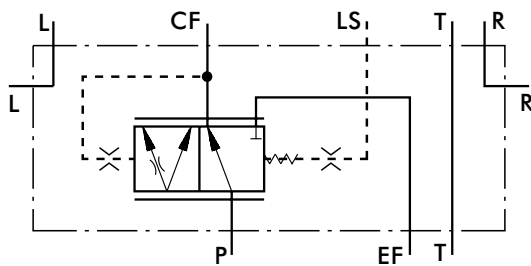

Static signal
PRD.../40,80...

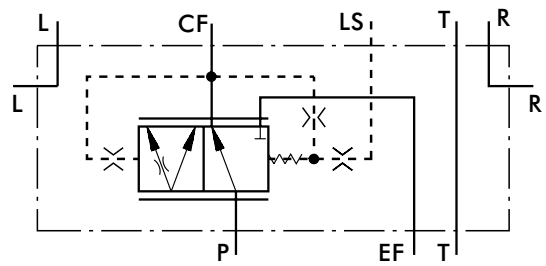

Dinamic signal
PRDD.../40,80...

Pipe Mounting

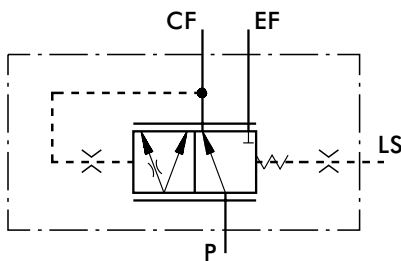

Static signal
PRT.../40,80...; PRTA.../40,80...

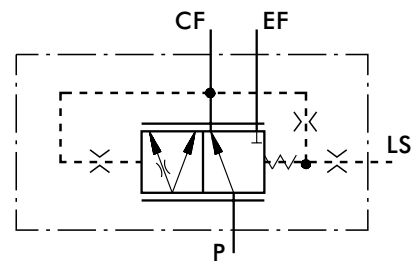

Dinamic signal
PRTD.../40,80...; PRTAD.../40,80...

PR...40

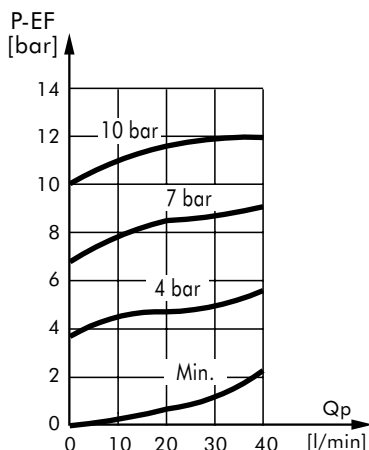

PR...80

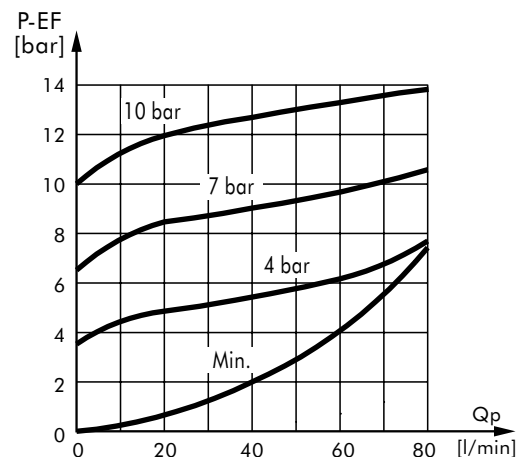

SPECIFICATION DATA

Parameters	Type					
	PRD(D), PRT(D)			PRTA(D)		
Rated Flow [l/min]	40; 80					
Control Spring Pressure [bar]	4	7	10	4	7	10
Max. Pressures in Oil Ports: P, EF, R, L [bar]	250					
LS, CF	175					
T	20					
Weight, avg. [kg]	2,7			1,2		

P - pump, **EF** - excess flow, **CF** - control flow (first priority oil flow),
L - left, **R** - right, **LS** - load sensing, **T** - tank

DIMENSIONS AND MOUNTING DATA - PRD(D)/ 40,80

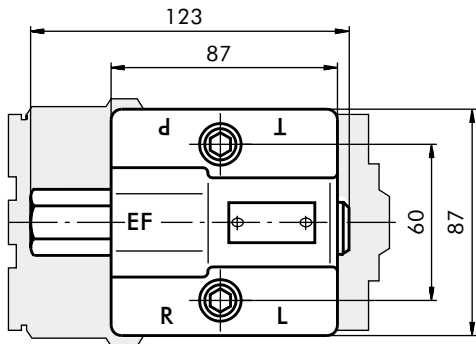
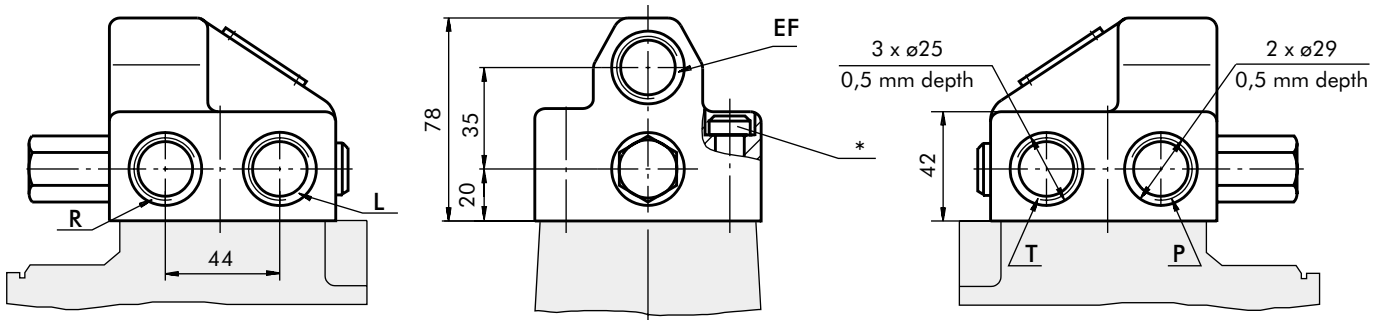

code	Ports - P, EF Thread	Ports - T, R, L Thread
-	G1/2 18 mm depth	G3/8 18 mm depth
M	M22x1,5 18 mm depth	M18x1,5 18 mm depth
A	7/8 - 14 UNF O-ring 18 mm depth	3/4 - 16 UNF O-ring 18 mm depth

* Connection to the HKUS.../5... is done with 2 screws M10x1x45-10.9 DIN 912 or with 2 screws 3/8-24 UNF ANSI B18.3-76; 44,5 mm long.
Tightening torque: 4,5±0,5 daNm.

DIMENSIONS AND MOUNTING DATA - PRT(D)/40,80

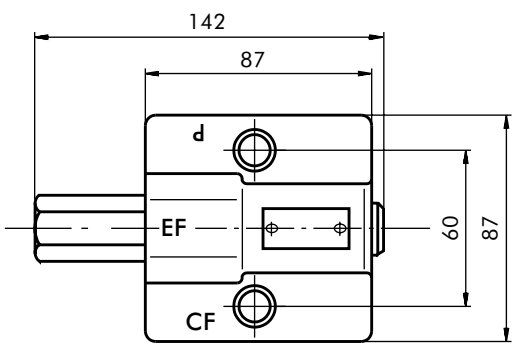
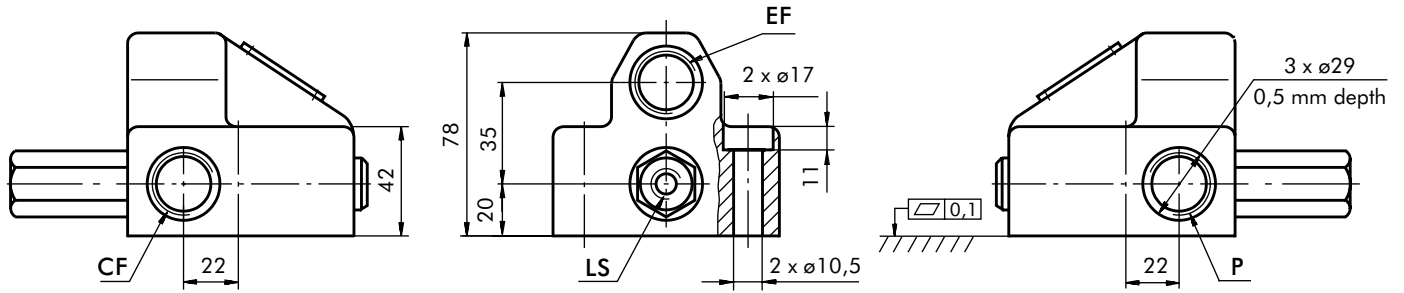

code	Ports - P, EF Thread	Port - CF Thread	LS - Port
-	G1/2 18 mm depth	G1/2 18 mm depth	G1/4 14 mm depth
M	M22x1,5 18 mm depth	M22x1,5 18 mm depth	G1/4 14 mm depth
A	7/8 - 14 UNF O-ring 18 mm depth	3/4 - 16 UNF O-ring 18 mm depth	7/16 - 20 UNF O-ring 12,7 mm depth

DIMENSIONS AND MOUNTING DATA - PRTA(D)/40,80

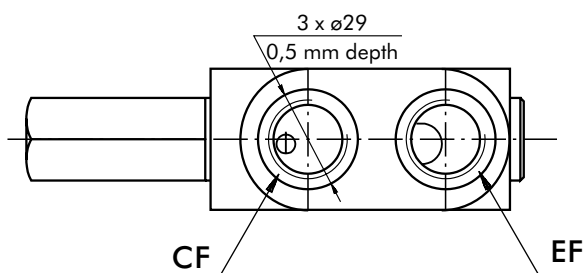
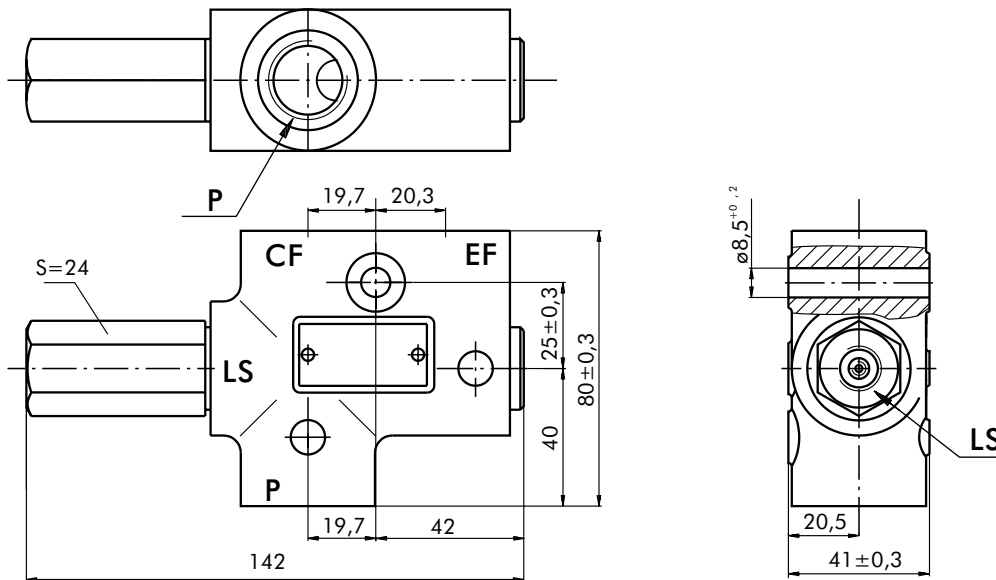

code	Ports - P, EF Thread	Port - CF Thread	LS - Port
-	G1/2 18 mm depth	G1/2 18 mm depth	G1/4 14 mm depth
M	M22x1,5 18 mm depth	M22x1,5 18 mm depth	G1/4 14 mm depth
A	7/8 - 14 UNF O-ring 18 mm depth	3/4 - 16 UNF O-ring 18 mm depth	7/16 - 20 UNF O-ring 12,7 mm depth

PRIORITY VALVES FOR HKUS.../5... TYPE PRT.../160



The Priority Valves PRT.../160 have built-in a pilot pressure relief valve, who protects the steering unit against excess pressure. The pilot pressure relief valve operates with the Shuttle of the Priority valve to limit the maximum steering pressure P-T measured across the steering units ports.

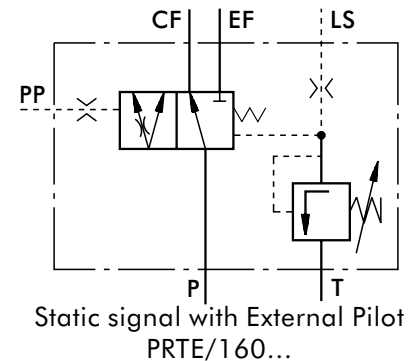
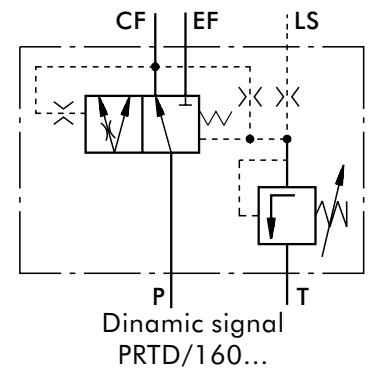
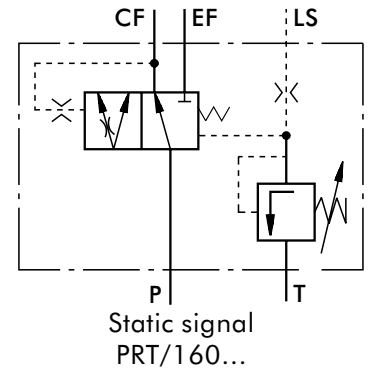

SPECIFICATION DATA

Parameters	Type		
	PRT(E), PRTD(E)		
Rated Flow [l/min]	160		
Control Spring Pressure [bar]	4	7	10
Max. Pressures in Oil Ports: [bar]	P, EF, R, L	250	
	LS, CF	210	
	T	15	
	PP	210	
Standart Relief Valve Pressure Settings [bar]	175*		
Weight, avg. [kg]	4,9		

* - Adjusted valve pressure from 80 till 210 bar upon customer request.

P - pump, **EF** - excess flow, **CF** - control flow (first priority oil flow),
L - left, **R** - right, **LS** - load sensing, **T** - tank, **PP** - pilot pressure

PRT...160

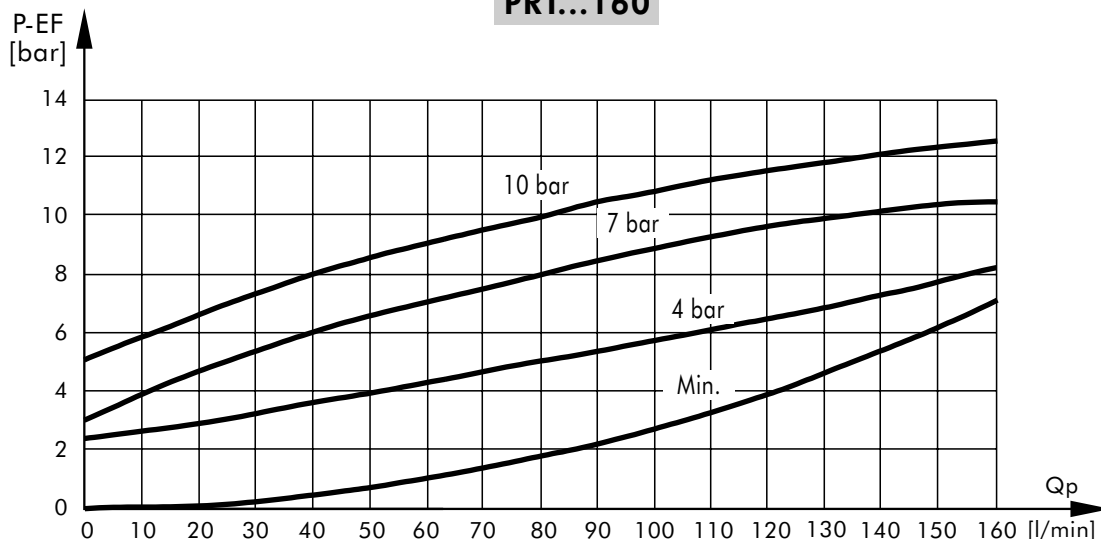

DIMENSIONS AND MOUNTING DATA - PRT/160

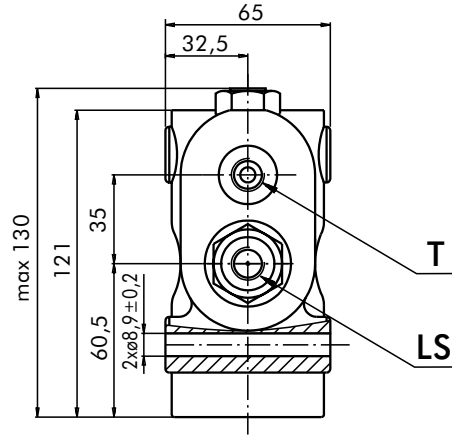
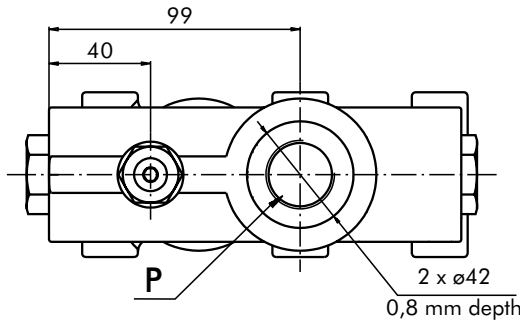
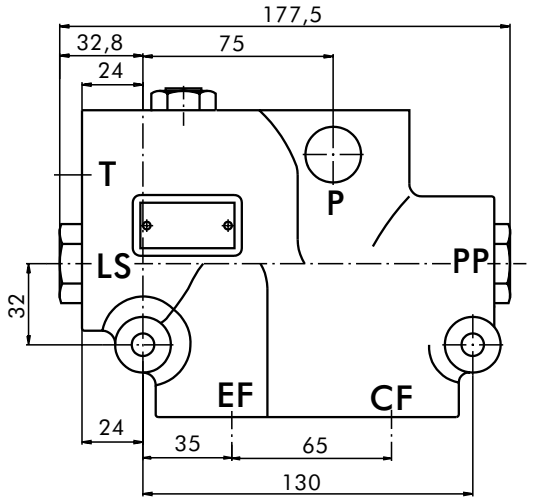
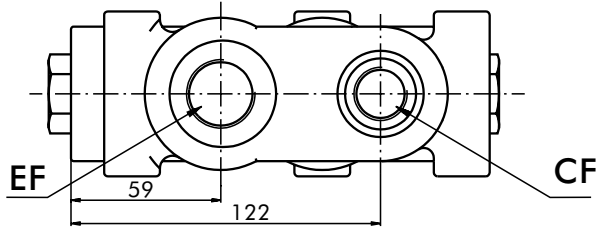

code	Ports - P, EF Thread	Port - CF Thread	LS, PP, T - Ports
-	G3/4 20,5 mm depth	G1/2 18,5 mm depth	G1/4 12,5 mm depth
A	1 1/16 - 12 UN O-ring 20,5 mm depth	3/4 - 16 UNF O-ring 18,5 mm depth	7/16 - 20 UNF O-ring 12,5 mm depth
M	M27x2 20,5 mm depth	M18x1,5 18,5 mm depth	M12x1,5 12,5 mm depth

ORDER CODE

1	2	3	4	5	6	7
P R			/	-		

Pos.1 - Mounting

- D** - Modularly Mounting
- T** - Pipe Mounting (Model 1)
- TA** - Pipe Mounting (Model 2)

Pos.2 - Signal Type

- omit - with Static signal
- D** - with Dinamic signal
- E*** - with Static signal w/ External Pilot

Pos.3 - Rated Flow, l/min

- 40** **80** **160****

Pos.4 - Control Spring Pressure , bar

- 4** **7** **10**

Pos.5 - Ports

- omit - BSPP (ISO 228)
- A** - SAE (ANSI B 1.1 - 1982)
- M** - Metric (ISO 262)

Pos.6 - Option (Paint)***

- omit - No Paint
- P** - Painted
- PC** - Corrosion Protected Paint

Pos.7 - Design Series

- omit - Factory specified

NOTES:* Only for PRT/160
****** Only for PRT
******* Colour at customer's request.

The priority valves are mangano-phosphatized as standard.

TORQUE AMPLIFIERS TYPE UVM...



The M+S Hydraulic UVM Torque Amplifiers amplify the applied torque to the control shaft and thus ease the running of various transport vehicles such as:

- agricultural and wood working machines;
- road rollers and road cleaning machines;
- fork-lift trucks and construction machinery;

The totally transferred power in terms of output torque is up to 1,1 kW.

The UVM torque amplifiers with their simple design, consisted of a pump and an amplifier, ensure 40 times higher output torque than the applied one. The amplifying is achieved as follows; by rotating the input shaft to the left or right the spool and the bushing are displaced, and the hydraulic flow enters the system turning the gerotor set, which transfers the already amplified torque to the output shaft.

One advantage of the UVM torque amplifier is that it allows manual steering in cases of engine (pump) failure.

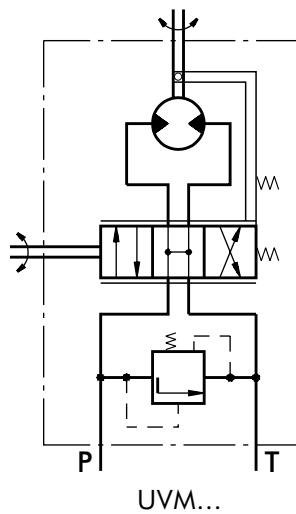

SPECIFICATION DATA

Parameters	Type	
	UVM 100	UVM 160
Displacement [cm ³ /rev]	99,0	158,4
Rated Flow* [l/min]	10	16
Rated Pressure** [bar]	70	70
Input Torque [Nm]	3,5...5	3,5...5
Max. Input Torque [Nm]	20	20
Torque Output at 70 bar. [Nm]	80	120
Pressure Drop between P and T at Rated Flow, [bar]	1 ... 2	1,6...2,5
Max. Speed of Rotation at Rated Flow and Pressure [RPM]	100	100
Max. Continuous Pressure in Line T [bar]	20	20
Weight, avg. [kg]	5,8	6,2

* Rated Flow at 100 RPM.

** Pressure Settings are at Rated Flow (as in the table) and viscosity 21 mm²/s (50° C).

DIMENSIONS AND MOUNTING DATA

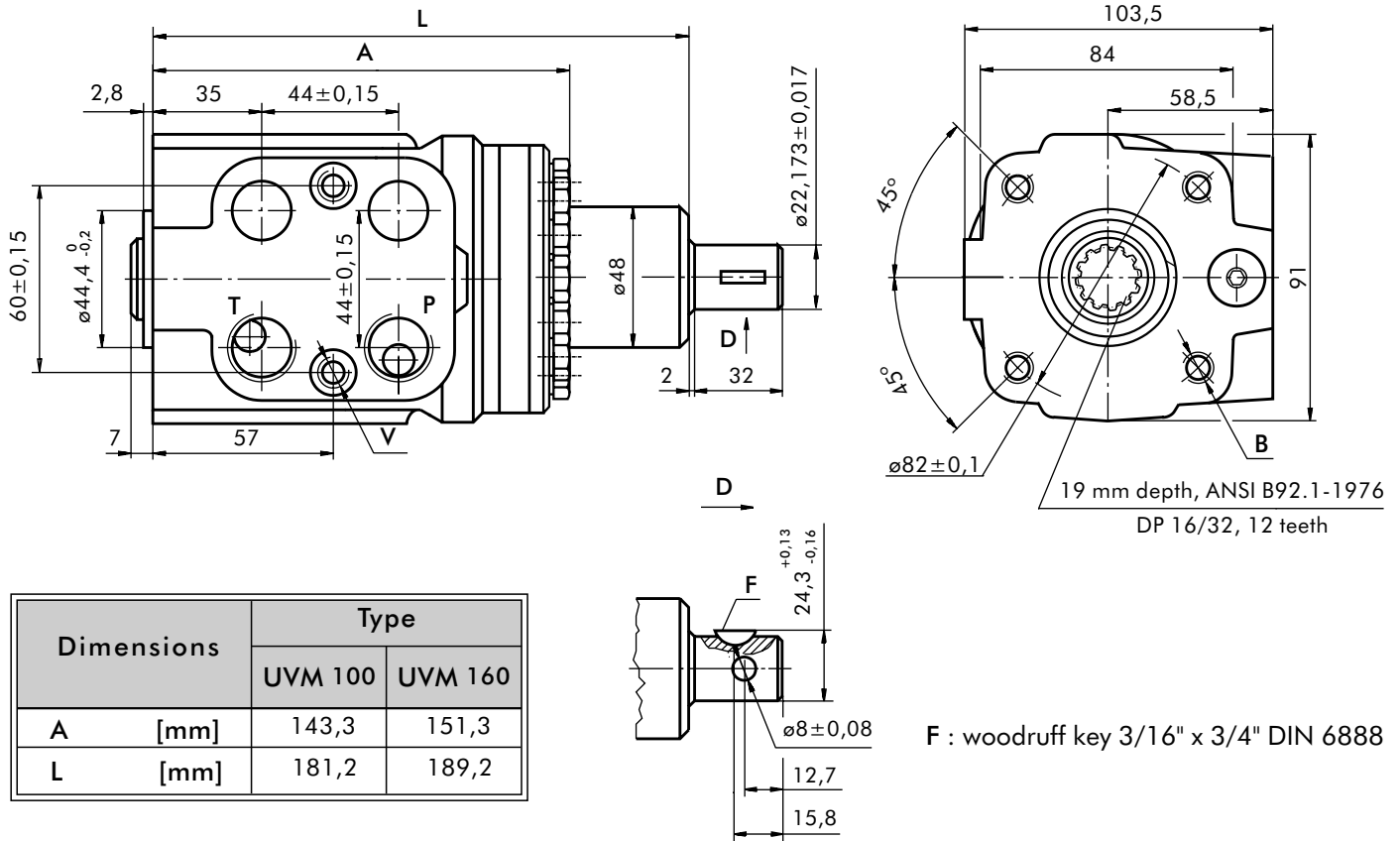

Dimensions	Type	
	UVM 100	UVM 160
A [mm]	143,3	151,3
L [mm]	181,2	189,2

code	Ports - P, T Thread	Column Mounting Thread - B	Port Mounting Thread - V
-	G1/2 17 mm depth	4 x M10 18 mm depth	2 x M10x1 16 mm depth
A	3/4 - 16 UNF O-ring 17 mm depth	4 x 3/8 - 16 UNC 15,7 mm depth	2 x 3/8 - 24 UNF 14,2 mm depth
M	M22x1,5 17 mm depth	4 x M10 18 mm depth	2 x M10x1 16 mm depth

ORDER CODE

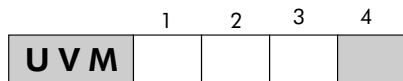

- Pos.1 - Displacement code**
- 100** - 99,0 [cm³/rev]
 - 160** - 158,4 [cm³/rev]
- Pos.2 - Ports**
- omit - BSPP (ISO 228)
 - A** - SAE (ANSI B 1.1 - 1982)
 - M** - Metric (ISO 262)

- Pos.3 - Option (Paint)***
- omit - No Paint
 - P** - Painted
 - PC** - Corrosion Protected Paint
- Pos.4 - Design Series**
- omit - Factory specified

NOTES:

* Colour at customer's request.
The steering units are mangano-phosphatized as standard.

STEERING COLUMNS TYPE KK...



The M+S Hydraulic KK Steering Columns transfer the torque from the steering wheel of the vehicle to the HKU, HKUS or other of the same class steering units. The KK steering columns are consisted of a pipe in which is centered the control shaft.

Permissible loads on the steering column are as follows:

Max. torque applied to the steering wheel	24 daNm
Max. bending moment	20 daNm
Max. axial load	100 daN

The steering column must be additionally supported when the length L exceeds 150 mm.

DIMENSIONS AND MOUNTING DATA

Type KK

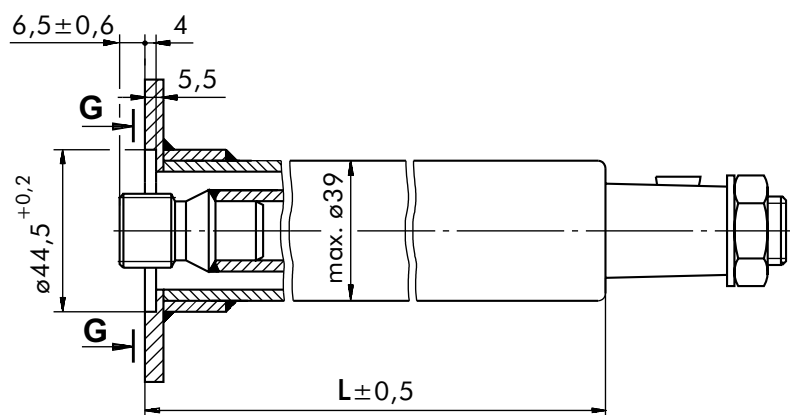
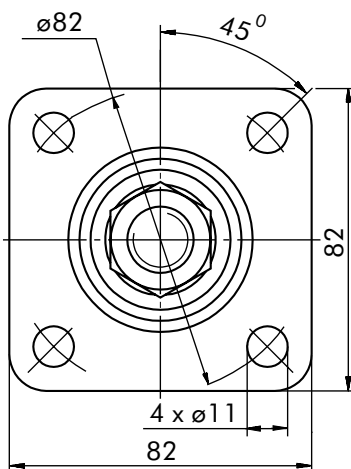

Type KKF

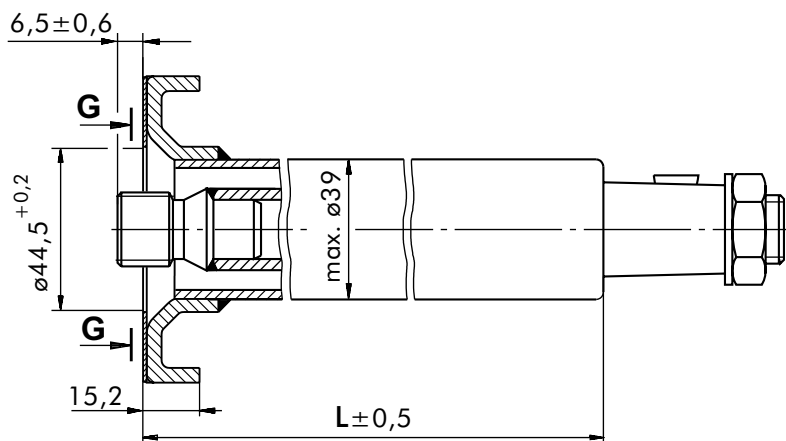
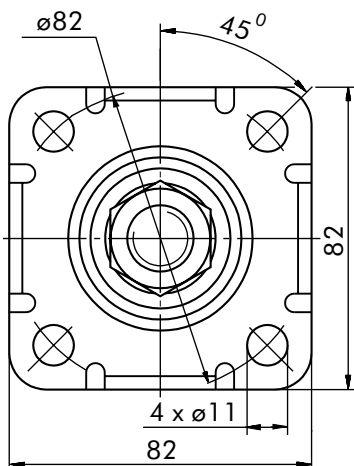

SPECIFICATION DATA

Parameters	Type			
	KK 75	KK 150	KK 390	KK 750
L, [mm]	78	168,2	393	777,8
Weight, [kg]	0,75	1,1	1,9	3,3

Please, contact factory or your regional manager regarding other lengths.

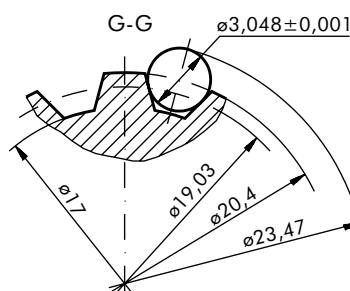

Involute Spline Data		
Modul	m	1,5875
Number of Teeth	z	12
Pressure Angle	α	30°
Pitch	p_t	4,986

SHAFT EXTENSIONS

TYPE I

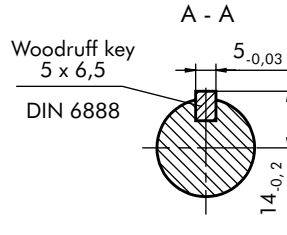
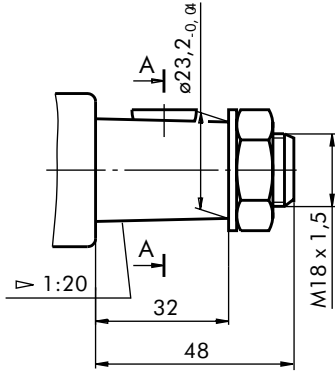

TYPE II

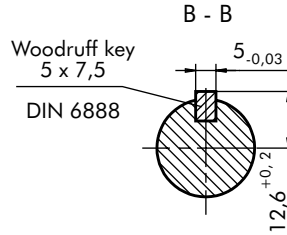
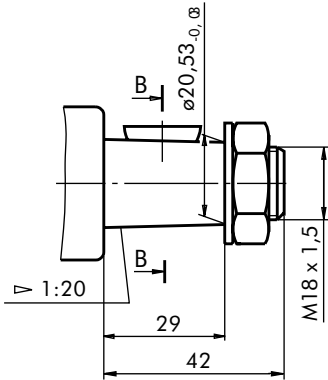

TYPE III

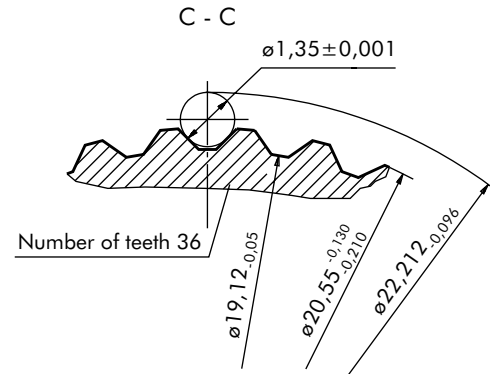
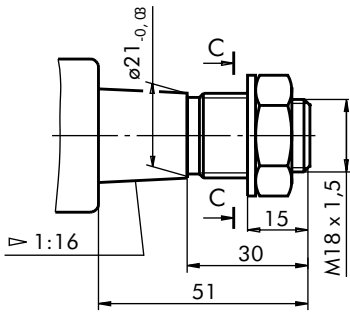

TYPE IV

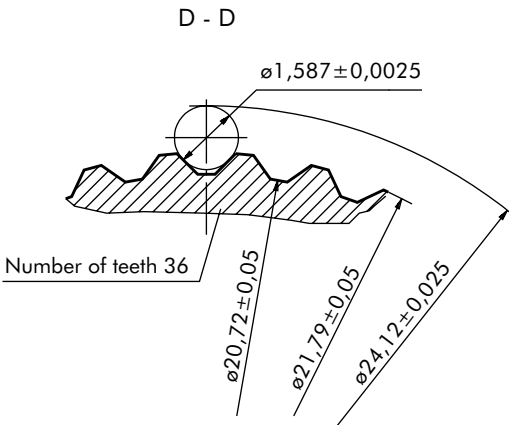
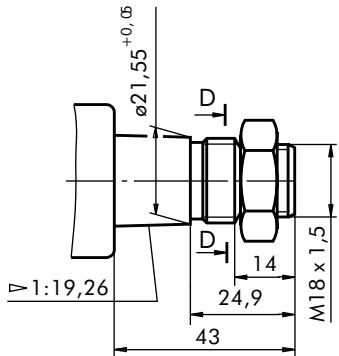

TYPE V

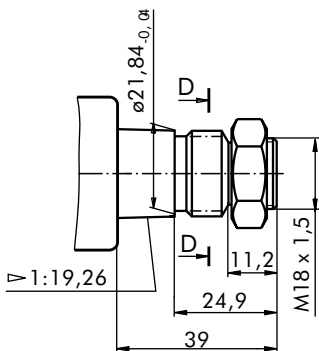

SHAFT EXTENSIONS

TYPE VI

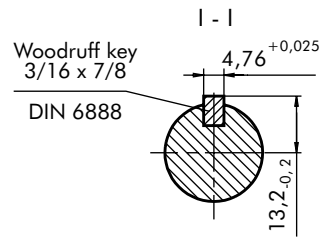
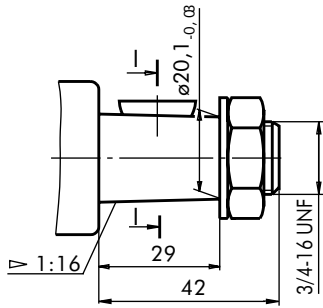

TYPE VII

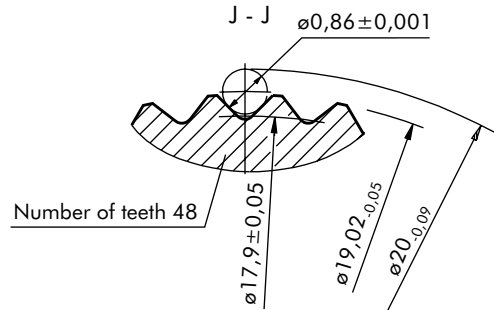
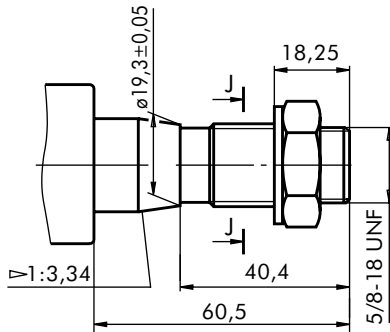

TYPE VIII

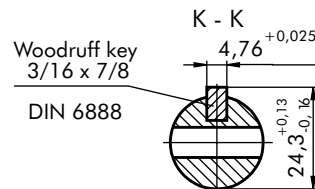
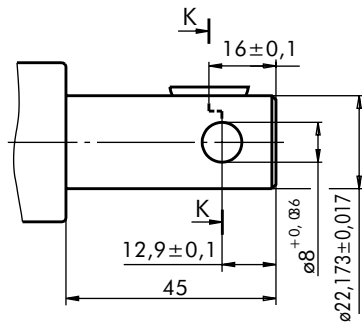

TYPE IX

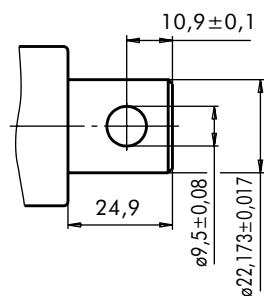

INSTALLING

For column type KK

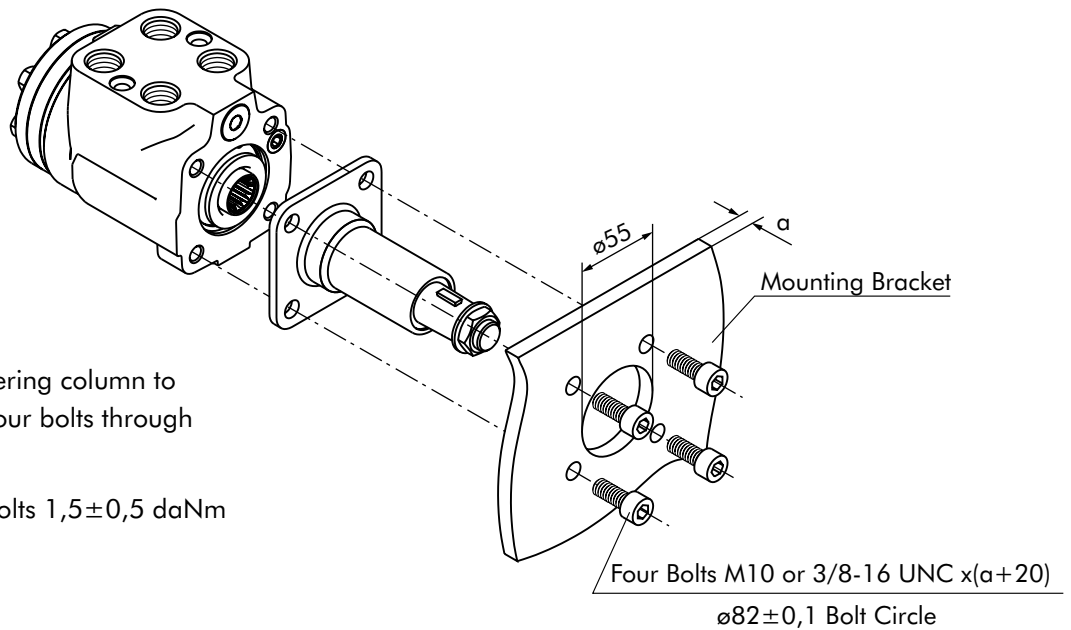

For assembling the Steering column to the Steering units use four bolts through mounting bracket.

Tightening torque for bolts $1,5 \pm 0,5$ daNm

For column type KKF

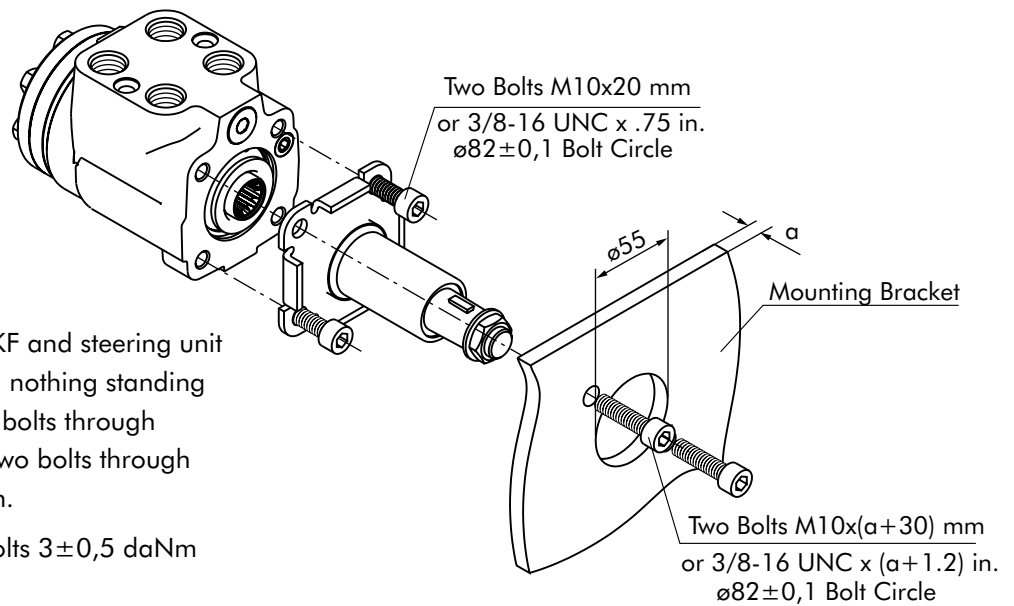

Steering column type KKF and steering unit must be assembled with nothing standing between them. Use two bolts through mounting bracket and two bolts through just the steering column.

Tightening torque for bolts $3 \pm 0,5$ daNm

Minimum Clearance at Assembly

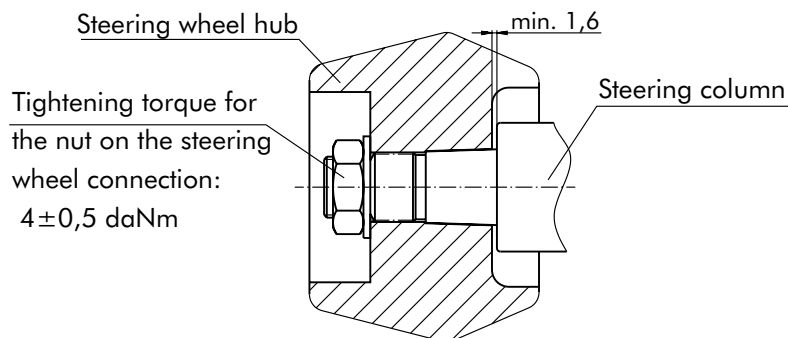

SOUND SIGNAL CONNECTION

E Option

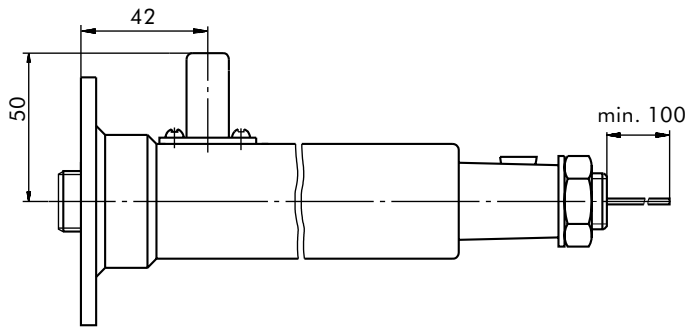

EE Option

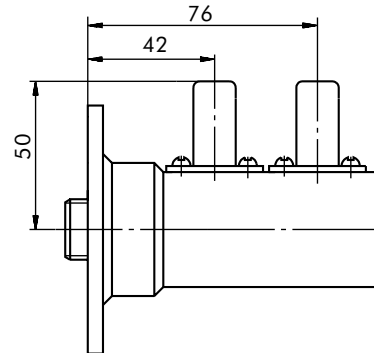

ORDER CODE

	1	2	3	4	5	6
KK						

Pos.1 - Mounting Flange

omit - Flange without Tabs

F - Flange with Tabs

Pos.2 - Length, mm (acc. to table)

Pos.3 - Shaft Extensions

I, II, III, IV, V, VI, VII, VIII, IX

Pos.4 - Signal Connection (Option)

omit - without electric signal connection

E - with one electric signal connection

EE - with two electric signal connection

Pos.5 - Option (Paint)*

omit - No Paint

P - Painted

PC - Corrosion Protected Paint

Pos.6 - Design Series

omit - Factory specified

NOTES:

* Colour at customer's request.

The steering columns are yellow galvanized as standard.

Shaft End Part

Order No:46415 001 00

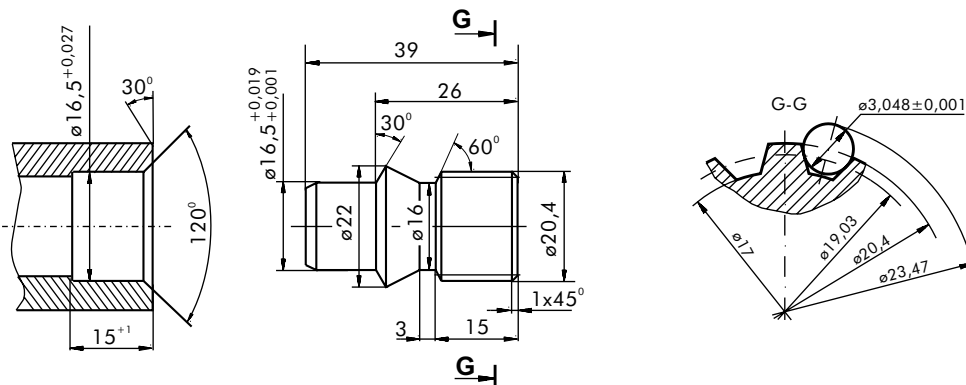

Involute Spline Data		
Modul	m	1,5875
Number of Teeth	z	12
Pressure Angle	α	30°
Pitch	p_t	4,986

HYDROSTATIC STEERING UNITS

GENERAL APPLICATION AND SPECIFICATION INFORMATION

APPLICATION

(SIZING AND STEERING SYSTEM DESIGN PROCESS)

STEP ONE:

Calculate approximate kingpin torque (M_L).

$$M_L = G \cdot \mu \sqrt{\frac{B^2}{8} + \ell^2}$$

Note: Double M_L if steered wheels are powered.

M_L = Kingpin torque in [daNm].

G = Vehicle weight on steered axle in [daN] (use maximum estimated overload weight).

μ = Coefficient of friction (use Chart No 1, dimensionless) determined by ℓ/B (see Diagram No 1).

B = Nominal width of tyre print [m] (see Diagram No 1).

ℓ = Kingpin offset. The distance between tyre centerline intersection at ground and kingpins centerline intersection at ground in [m] (see Diagram No 1).

Chart No 1

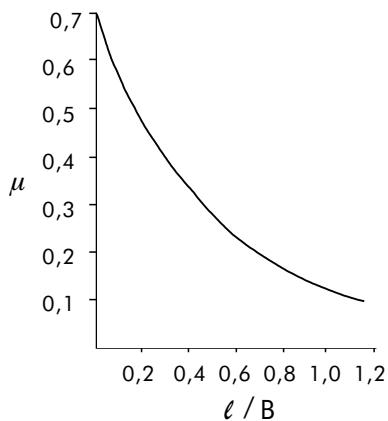

Diagram No 1

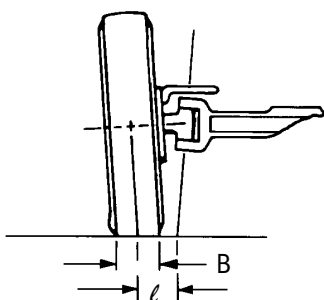
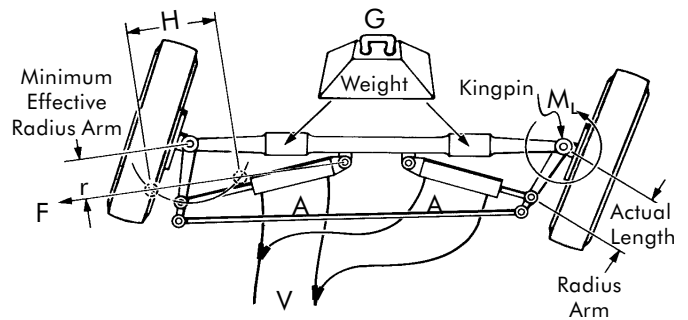

Diagram No 2



STEP TWO:

Calculate approximate cylinder; force-area-stroke-volume.

FORCE

$$F = \frac{M_L}{r}$$

F = Force required [daN] to steer axle.

M_L = Kingpin torque in [daNm] from step one. Double M_L if steered wheels are powered.

r = Effective radius Arm [mm] is the minimum distance from the centerline of the cylinders minimum and maximum stroke points parallel to the kingpin center pivot. This is not the physical length of the radius Arm (see Diagram No 2 and Chart No 2).

Chart No 2

$$r_{\min} = r_{\max} \cdot \cos \frac{\gamma}{2}$$

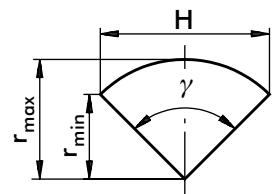

STROKE

H = Stroke [cm].

Calculate stroke of cylinder using Diagram No 2 and Chart No 2 as shavt.

$$H = 2 r_{\max} \cdot \sin \frac{\gamma}{2}$$

AREA

$$A = \frac{F}{\Delta P}$$

A = Cylinder area for axle cylinder set [cm²].

F = Force required from step two force formula [daN].

ΔP = Hydraulic pressure [bar] use following percentage of relief valve setting by amount of load on steered axle. Severe load 25% - medium load 55% - no load 75%.

DIAMETER

After the cylinder set area is determined, the cylinder diameter can be calculated.

D = Inside diameter of cylinder [cm].
d = Road diameter of cylinder [cm].

Choose type of cylinder arrangement and formula shown for that type.

Differential Cylinder

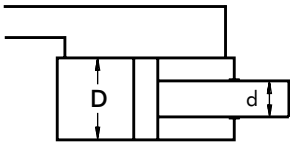

$$D = \sqrt{\frac{4A}{\pi} + d^2}$$

Note: $\left(\frac{d}{D}\right)^2 \leq 0,15$

Cross Connected Cylinders

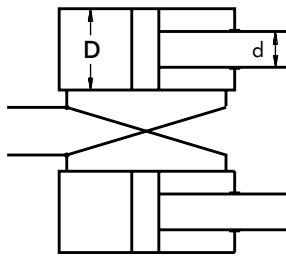

$$D = \sqrt{\frac{2A}{\pi} + \frac{d^2}{2}}$$

Balanced Cylinder

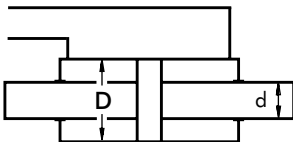

$$D = \sqrt{\frac{4A}{\pi} + d^2}$$

Opposed Cylinder

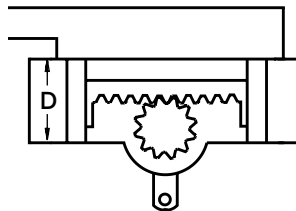

$$D = \sqrt{\frac{4A}{\pi}}$$

VOLUME $V = H \cdot A$

V = Volume. The total amount of oil required to move the cylinder rod(s) through the entire stroke [cm³].

H = Stroke [cm].

A = Area [cm²].

Note: For differential cylinders it is important to calculate average cylinder volume for step three using below formula.

$$V_{avg} = H \cdot \frac{\pi}{4} (2D^2 - d^2)$$

STEP THREE:

Selecting displacement of hydrostatic steering unit.

At this point determine number of steering wheel revolutions desired for your application to steer the wheels from one side to the other (lock to lock). Depending on the type of vehicle and its use, this will vary from 3 to 5 turns.

DISPLACEMENT $V_D = \frac{V}{n}$

V_D = Displacement [cm³] per rev.

V = Volume of oil [cm³].

n = Steering wheel turns lock to lock.

After completing the above displacement calculation, choose the closest standard hydrostatic steering unit in displacement size that incorporates circuitry you require.

Recalculate the number of steering wheel turns using the displacement of selected standard hydrostatic steering unit outlined above. Use the formula shown below.

$$n = \frac{V}{V_D}$$

V = Volume of oil [cm³].

n = Steering wheel turns lock to lock.

Note: For differential cylinders applications the cylinder volume will be different for left and right turns - this means the value n (steering wheel turns lock to lock) will vary when turning to the left or right.

STEP FOUR:

Calculate approximate minimum and maximum steering circuit flow requirements.

$$Q = \frac{V_D}{\text{Unit Conversion for Imperial or [1000] Metric}}$$

Q = Steering circuit flow [l/min].

V_D = Unit displacement [cm³] per rev.

N = Steering wheel input speed [rpm] (min⁻¹).

Recommended steering speed is 50 to 100 rpm.

Many variables are involved in sizing the pump. We suggest that the manufacturer test and evaluate for desired performance.

GENERAL INFORMATION

FLUID DATA:

To insure maximum performance and life of the Hydrostatic steering units, use premium quality hydraulic oils. Fluids with effective quantities of anti-wear agents or additives are highly recommended. If using synthetic fluids consult the factory for alternative seal materials.

Viscosity

Viscosity at normal operating temperature should be approx. 20 mm²/s. Viscosity range 10 - 300 mm²/s.

Temperature

Normal operating temperature range from +30°C to +60°C.

Minimum operating temperature -40°C.

Maximum operating temperature +80°C.

Note: Extended periods of operation at temperature of 60°C and above will greatly reduce life of oil due to oxidation and shorten life of product.

Filtration

The maximum degree of contamination per ISO 4406 or CETOP RP is:

- 20/17 open center units
- 19/16 closed center and load sensing
- 16/12 priority valves

Return line filtration of 25 μm nominal (40 - 50 μm absolute) or finer is recommended.

In extremely dusty conditions filtration of 10 μm absolute should be used.

START UP

All air must be purged from system before operating unit. It is extremely important that any external lines or units with load sensing or priority feature be completely bled. Lines going to and from cylinders as well as lines to and from pump be purged of all air. It is recommended that a 10 - 15 mm filter be used between pump and steering unit before start up.

MOUNTING UNITS

All hydrostatic steering units should be installed for ease of access. It is recommended that the steering unit be located outside the vehicle cabin.

It is important that no radial axial load be applied to the hydrostatic steering unit input shaft. Any or all radial and axial loads must be absorbed by the steering column or other operating device supplied by the vehicle manufacture.

Ports on the steering cylinder(s) should face upward to prevent damage.

During installation of the hydrostatic steering unit, cleanliness is of the utmost importance. Pipe plugs should be left in place during mounting and only removed when hydraulic lines are to be connected.

TORQUE TIGHTENING VALUES

Fluid connections

Fluid connection	Max. tightening torque daNm			
	metal edge	copper washer	aluminum washer	O - ring
7/16 - 20 UNF				2
9/16 - 18 UNF				5
3/4 - 16 UNF				6
7/8 - 14 UNF				7
G 1/4	4	2	3	
G 3/8	6	2	5	
G 1/2	10	3	8	
G 3/4	16	5	13	
M 10 x 1	4	2	3	
M 18 x 1,5	7	2	5	
M 22 x 1,5	10	3	8	

Mounting bolts

Mounting bolts	Tightening torque daNm
3/8 - 16 UNC	3,0 ± 0,5
M 10 x 1	6,5 ± 0,5
M 10	3,0 ± 0,5

WARRANTY

M+S Hydraulic warrants , what it's products are free of defects in material or workmanship . This warranty will apply only to defects appearing within 2 years after the date of production of the product. If Customer notify M+S Hydraulic within the above period about any such defects, M+S , at its sole option will replace or repair the defective products .

THE FOREGOING LIMITED WARRANTY IS AVAILABLE ONLY IF "M+S HYDRAULIC" IS PROMPTLY NOTIFIED IN WRITING OF THE ALLEGED DEFECT AND DOES NOT COVER FAILURE TO FUNCTION CAUSED BY DAMAGE TO THE PRODUCT, IMPROPER INSTALLATION, UNREASONABLE USE OR ABUSE OF THE PRODUCT, FAILURE TO PROVIDE OR USE OF IMPROPER MAINTENANCE OR USUAL, DEGRADATION OF THE PRODUCT DUE TO PHYSICAL ENVIRONMENTS OF AN USUAL NATURE. THE FOREGOING REMEDIES ARE THE SOLE AND EXCLUSIVE REMEDIES AVAILABLE TO CUSTOMER .

LIMITATION OF LIABILITY M+S Hydraulic's liability for any claim of any kind , for any loss or damage arising out of, connected with or resulting from an order, or from the performance or branch thereof, or from the design, manufacture, sale delivery, operation or use of any of its products shall be limited to , at M+S 's sole option, replacement, repair of any defective product or the issuance of a credit to Customer against any future purchases. Cash refunds will not be made under any circumstances and Customer will not be entitled to recover any damages of any kind against M+S Hydraulic, including but not limited to incidental or consequential damages, whether direct or indirect, known or unknown, foreseen or unforeseen.